Swale

Family

Armchair

Designer

Gordon Guillaumier / 2020

Link

www.read-mo.re/swale



SWALE

Dati tecnici · Technical data · Données techniques · Technische Angaben

Legs

Upholstered base

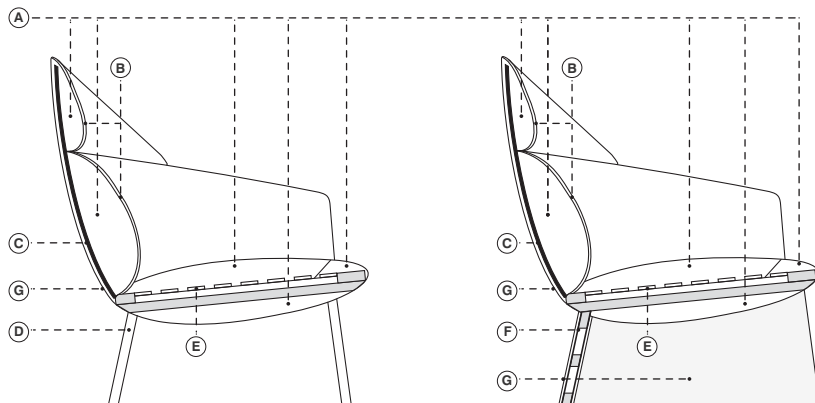

- Legno massiccio di faggio
- A. Poliuretano espanso ignifugo indeformabile a quote differenziate
- B. Fibra di poliestere
- C. Vetroresina
- D. Acciaio verniciato
- E. Cinghie elastiche ad alta densità
- F. Pannello di masonite
- G. Rivestimento fisso in tessuto o pelle

- Solid beech
- A. Flame-retardant undeformable polyurethane foam of different densities
- B. Polyester fibers
- C. Fibreglass
- D. Lacquered steel
- E. High density elastic straps
- F. Masonite panels
- G. Fixed upholstery in fabric or leather

- Bois de hêtre massif
- A. Mousse polyuréthane expansé ignifuge indéformable à épaisseurs différenciées
- B. Fibre de polyester
- C. Fibre de verre
- D. Acier laqué
- E. Sangles élastiques
- F. Panneau de particules
- G. Revêtement pas déhoussable en tissu ou cuir

- Massiveholz aus Buche
- A. Feuerfesterformbeständige Polyurethanschaum in unterschiedlicher Dichte
- B. Polyester
- C. Glasfaserkunststoff
- D. Lackierter Stahl
- E. Elastischen Gurtbändern
- F. Holzfaserplatte
- G. Unabziehbarer Bezug aus Stoff oder Leder

Note · Notes · Annotation · Anmerkung

- Basi personalizzabili con tinta cliente
- Cuscini extra disponibili
- COM: tessuto cliente (tinta unita e h.140 cm.) - campione richiesto
- COL: pelle cliente - campione richiesto
- CAT. SPECIAL: prezzo e disponibilità su richiesta

- Bases customizable with customer's colors on request
- Extra cushions available
- COM: client's fabric (plain colour and width 140 cm.) - sample required
- COL: client's leather - sample required
- CAT. SPECIAL: price and availability upon request

- Piètements personnalisable avec coloris du client sur demande
- Autres coussins disponibles
- COM: tissu fourni (couleur unie et hauteur 140 cm.) - échantillon nécessaire
- COL: cuir fourni - échantillon nécessaire
- CAT. SPECIAL: prix et disponibilité sur demande

- Gestell in Kundenfarben auf Anfrage verfügbar
- Weitere Kissen verfügbar
- COM: Kundenstoff (einfarbig und Breite 140 cm.) - Stoffmuster nötig
- COL: Kundenleder - Ledermuster nötig
- CAT. SPECIAL: Preis und Verfügbarkeit auf Anfrage

Finitura base · Base finish · Finition de piètement · Gestell Ausführung



Avorio
Ivory
Ivoire
Elfenbein



Fango
Mud
Boue
Schlamm



Prugna
Plum
Prune
Pflaume



Nero pece
Pitch black
Poix noir
Pech Schwarz

Rivestimenti consigliati · Recommended coverings · Revêtements conseillées · Empfohlene Bezüge

- cat. A XTREME
- cat. A STEP
- cat. A CRAZY
- cat. B SILVERTEX
- cat. B SAMAR
- cat. B FAME
- cat. B MAIN LINE FLAX

- cat. C TREND
- cat. C DEANS
- cat. super REMIX 3
- cat. super CAPTURE
- cat. super BREEZE FUSION
- cat. extra MOLLY
- cat. extra RIME

- cat. extra STEELCUT TRIO 3
- cat. extra COLLINE
- cat. extra OPERA
- cat. extra DANTE
- cat. extra MOSAIC 2
- cat. maxi HALLINGDAL 65
- cat. maxi COMFORT

- cat. maxi DIVINA 3
- cat. lux LUX 1
- cat. lux LUX 2
- cat. imperial IMPERIAL 1
- cat. imperial IMPERIAL 2
- cat. special DROP

cod. 1150 / high armchair with legs

cod. 1151 / low armchair with legs

cod. 1152 / high armchair with uph. base

cod. 1153 / low armchair with uph. base



98 cm
38 5/8"



80 cm
31 1/2"



98 cm
38 5/8"



80 cm
31 1/2"



98 cm
38 5/8"



80 cm
31 1/2"



98 cm
38 5/8"

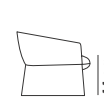

80 cm
31 1/2"

La Cividina s.r.l., al fine di migliorare caratteristiche tecniche e qualitative della sua produzione, si riserva di apportare, anche senza preavviso, tutte le modifiche che si rendessero necessarie.

With a view to improving the technical characteristics and quality of its products, La Cividina s.r.l. reserves the right to develop its products at anytime without notice.

Afin d'améliorer les caractéristiques techniques et qualitatives de sa production, La Cividina s.r.l. se réserve d'apporter, même sans préavis, toutes les modifications qui se rendront nécessaires.

Zur Verbesserung der technischen und qualitativen Merkmale, behält sich La Cividina s.r.l. vor, alle notwendig erscheinenden Produktionsänderungen, auch ohne Vorankündigung durchzuführen.



ISO 9001

LaCividina srl

**HEADQUARTERS
/ PRODUCTION**

Via Cividina 176
33035 Martignacco
Udine Italy

SHOWROOM

Via Lungolavia 1
33035 Martignacco
Udine Italy

T. + 39 0432 677433

F. + 39 0432 677480

info@lacividina.com

www.lacividina.com

VAT nr. IT01810870301