

NAP

Armchair, Sofa, Dormeuse
Ottoman, System

Andrea Steidl,
2019

laCividina



**DATI TECNICI
TECHNICAL DATA
DONNÉES TECHNIQUES
TECHNISCHE ANGABEN**

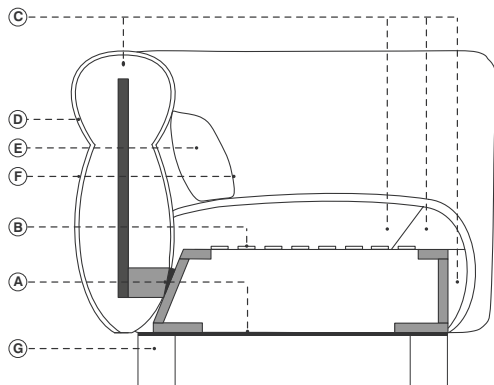

- | | | | |
|---|---|--|---|
| <ul style="list-style-type: none"> ■ Legno massiccio di faggio ■ Multistrato di faggio A. Acciaio B. Cinghie elastiche ad alta densità C. Poliuretano espanso ignifugo indeformabile a quote differenziate D. Fibra di poliestere E. Piuma e fibra di poliestere elicoidale F. Rivestimento sfoderabile in tessuto e non sfoderabile in pelle e finta pelle G. Legno di frassino | <ul style="list-style-type: none"> ■ Solid beech ■ Multilayered beech A. Steel B. High density elastic straps C. Flame-retardant undeformable polyurethane foam of different densities D. Polyester fibers E. Feathers and helical polyester fibers F. Removable upholstery in fabric and fixed in leather or artificial leather G. Ash wood | <ul style="list-style-type: none"> ■ Bois de hêtre massif ■ Multiplis de hêtre A. Acier B. Sangles élastiques C. Mousse polyuréthane expansé ignifuge indéformable à épaisseurs différenciées D. Fibre de polyester E. Plume et fibre de polyester hélicoïdal F. Revêtement déhoussable en tissu et pas déhoussable en cuir ou simili cuir G. Bois de frêne | <ul style="list-style-type: none"> ■ Massivholz aus Buche ■ Buchenschichtholz A. Stahl B. Elastischen Gurtbändern C. Feuerfester formbeständige Polyurethanschäum in unterschiedlicher Dichte D. Polyester E. Daunen und Polyesterfaser spiralförmig F. Abziehbarer Bezug aus Stoff und unziehbarer aus Leder und Kunstleder G. Eschenholz |
|---|---|--|---|

**NOTE
NOTES
ANNOTATION
ANMERKUNG**

- | | | | |
|---|---|--|--|
| <ul style="list-style-type: none"> ■ Rivestimento in tessuto sfoderabile, ad eccezione delle versioni in ecopelle e pelle ■ Cuscini extra disponibili ■ COM: tessuto cliente (tinta unita e h.140 cm.) - campione richiesto ■ COL: pelle cliente - campione richiesto | <ul style="list-style-type: none"> ■ All covers are removable with the exception of ecolather and leather versions ■ Extra cushions available ■ COM: client's fabric (plain colour and width 140 cm.) - sample required ■ COL: client's leather - sample required | <ul style="list-style-type: none"> ■ Revêtement en tissu déhoussable, à l'exception des versions en simili-cuir et cuir ■ Autres coussins disponibles ■ COM: tissu fourni (couleur unie et hauteur 140 cm.) - échantillon nécessaire ■ COL: cuir fourni - échantillon nécessaire | <ul style="list-style-type: none"> ■ Stoffbezug abziehbar, ausgenommen Kunstleder- und Lederausführungen ■ Weitere Kissen verfügbar ■ COM: Kundenstoff (einfarbig und Breite 140 cm.) - Stoffmuster nötig ■ COL: Kundenleder - Ledermuster nötig |
|---|---|--|--|

**FINITURE
FINISHES
FINITIONS
AUSFUHRUNGEN**



Frassino naturale
Natural ash
Frêne naturel
Eschenholz Naturfarbe



Frassino tinto grafite
Graphite-stained ash
Frêne teinté graphite
Eschenholz Graphit gebeizt

**RIVESTIMENTI CONSIGLIATI
RECOMMENDED COVERINGS
REVÊTEMENTS CONSEILLÉS
EMPFOHLENE BEZÜGE**

CAT. START
RINGO
OPUS

CAT. A
XTREME
TAILOR
ANGEL
MEDLEY
SAMAR
AVON
MAGNUM
AUTUMN
HANGO

CAT. B
FAME
MAIN LINE FLAX
HESTAN
SILVERTEX
GEIKO

CAT. C
SUPERB
TREND
KEN BI

CAT. SUPER
ORSETTO
REMIX 3
MYLLA
TWISTED FLOWER
DHARMA DIS.400
DHARMA DIS.200
DHARMA DIS.600
DHARMA DIS.100
DHARMA DIS.500
DIVA DIS.01

CAT. EXTRA
STEELCUT TRIO 3
ARIANA
OPERA
ARCO
CREDO
TRIO
BIT
DIVA DIS.05
DIVA DIS.21
DIVA DIS.29

CAT.MAXI
UNIFORM MÉLANGE
HALLINGDAL 65
DIVINA 3

CAT. TOP
ARDA
REGOS

CAT. SPECIAL
GENTLE 2

CAT. LUX
LUX 1
LUX 2

CAT. IMPERIAL
IMPERIAL 1
IMPERIAL 2

**POLTRONE
ARMCHAIRS
FAUTEUILS
SESSEL**

**COD.1070
ARMCHAIR**

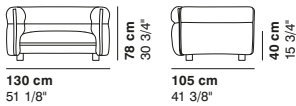

**DIVANI
SOFAS
CANAPES
SOFAS**

**COD.1071
2 SEATER SOFA**

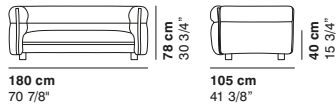

**COD.1072
3 SEATER SOFA**

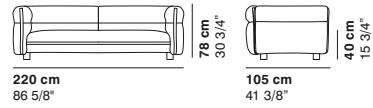

**COD.1073
3 SEATER SOFA MAJOR**

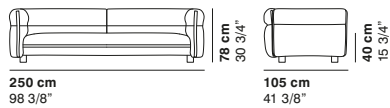

**COD.1074
4 SEATER SOFA**

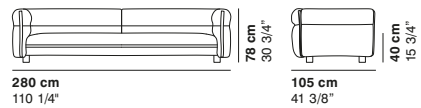

**COMPOSIZIONI
COMPOSITIONS
COMPOSITIONS
KOMPOSITIONEN**

**COD.1075SXN
LEFT ELEMENT**

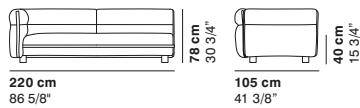

**COD.1076DXN
4 SEATER**

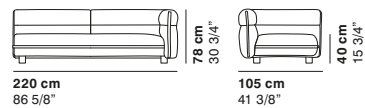

**COD.1075SXN
LEFT ELEMENT**

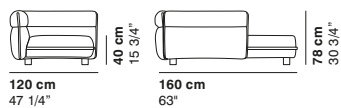

**COD.1076DXN
4 SEATER**

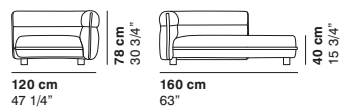

**POUF
OTTOMAN
POUF
HOCKER**

**COD.1077SXN
OTTOMAN 100**

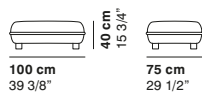

**COD.1078DXN
OTTOMAN 140**

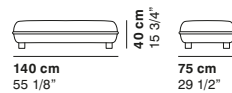

COD. NAP01
COMPOSITION

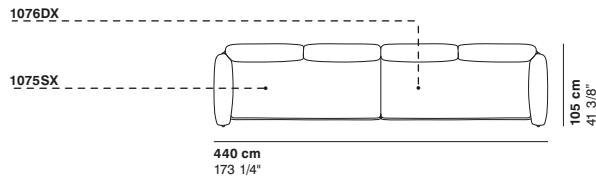

COD. NAP02DX
COMPOSITION

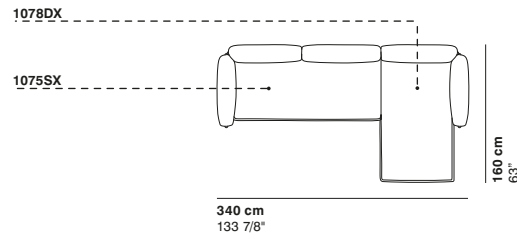

COD. NAP03SX
COMPOSITION

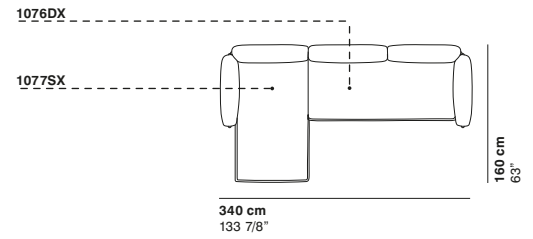

COD. NAP04
COMPOSITION

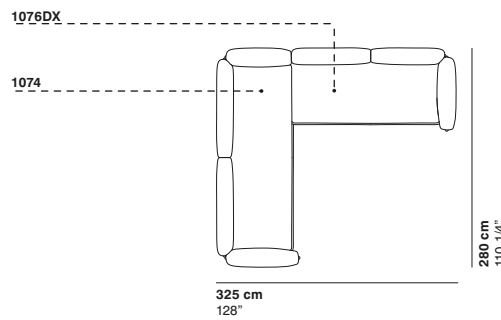

COD. NAP05
COMPOSITION

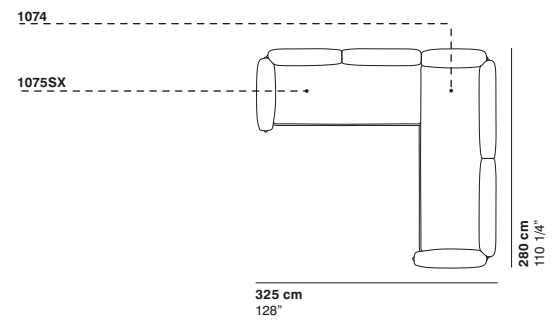

COD. SUI006SX
COMPOSITION

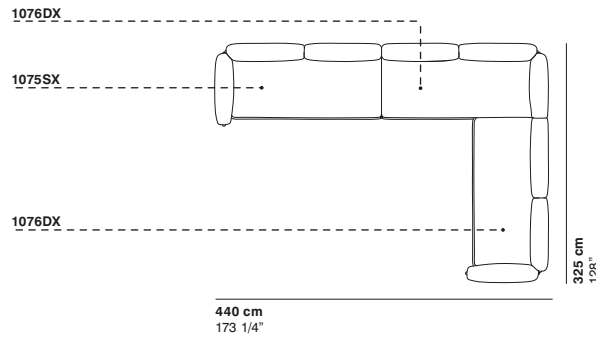

COD. SUI07DX
COMPOSITION

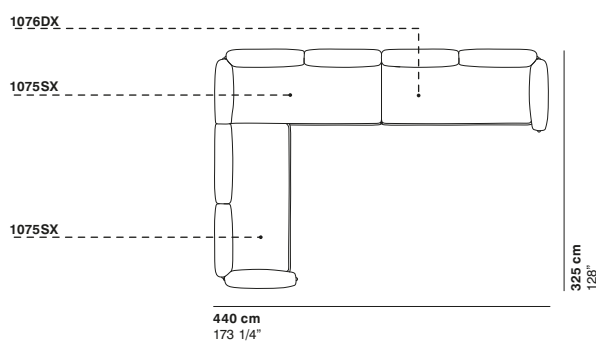

COMPOSIZIONI
COMPOSITIONS
COMPOSITIONS
KOMPOSITIONEN

COD. 1090
ARMCHAIR WITH CUSHIONS

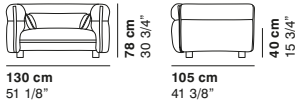

DIVANI
SOFAS
CANAPES
SOFAS

COD.1091
2 SEATER SOFA WITH CUSHIONS

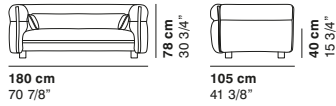

cod. 1092 / 3 seater sofa with cushions

COD.1092
3 SEATER SOFA WITH CUSHIONS

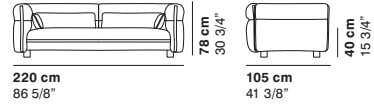

COD.1093
3 SEATER SOFA MAJOR WITH CUSHIONS

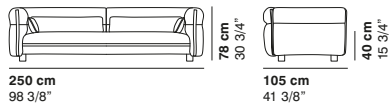

COD. 1094
4 SEATER SOFA WITH CUSHIONS

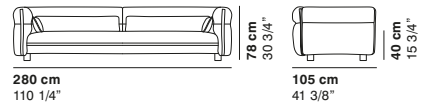

COMPOSIZIONI
COMPOSITIONS
COMPOSITIONS
KOMPOSITIONEN

COD. 1095SXN
LEFT ELEMENT 220 WITH CUSHIONS

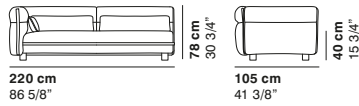

COD. 1096DXN
RIGHT ELEMENT 220 WITH CUSHIONS

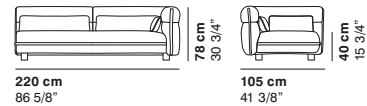

COD. 1097SXN
LEFT DORMEUSE WITH CUSHIONS

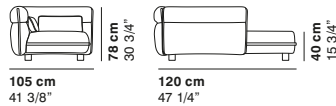

COD.1098DXN
RIGHT DORMEUSE WITH CUSHIONS

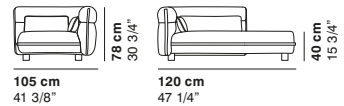

POUF
OTTOMAN
POUF
HOCKER

COD.1077SXN
OTTOMAN 100

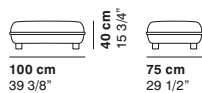

COD.1078DXN
OTTOMAN 140

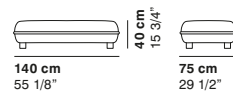

COD. NAP01-C
 COMPOSITION WITH CUSHIONS

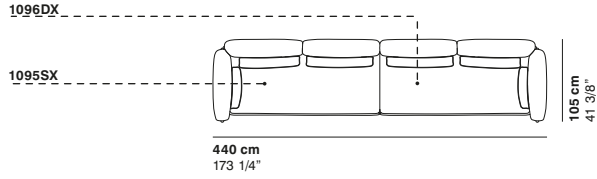

COD. NAP02DX-C
 COMPOSITION WITH CUSHIONS

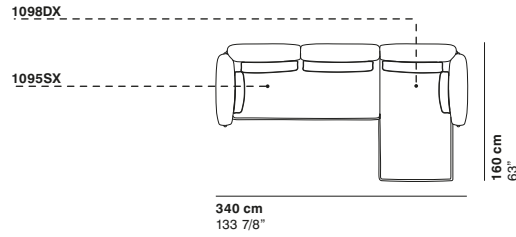

COD. NAP03SX-C
 COMPOSITION WITH CUSHIONS

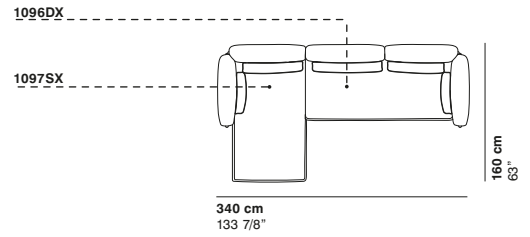

COD. NAP04-C
 COMPOSITION WITH CUSHIONS

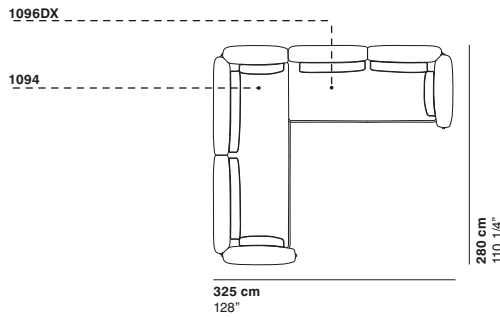

COD. NAP05-C
 COMPOSITION WITH CUSHIONS

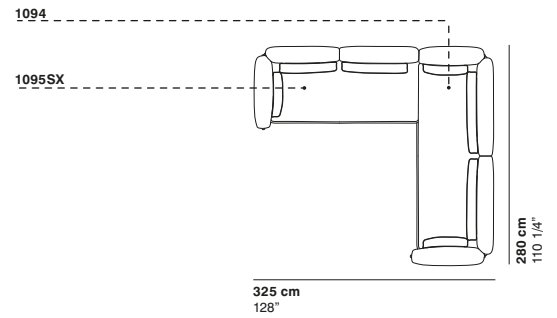

COD. SUI006SX-C
 COMPOSITION WITH CUSHIONS

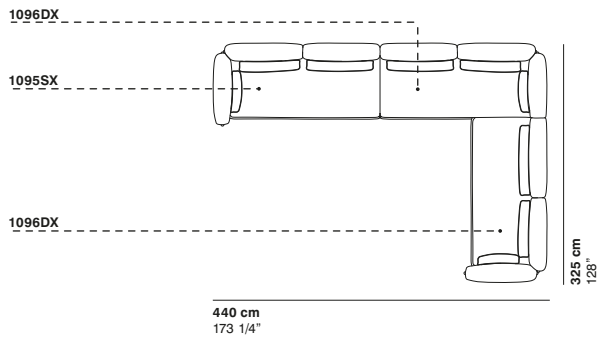

COD. SUI07DX-C
 COMPOSITION WITH CUSHIONS

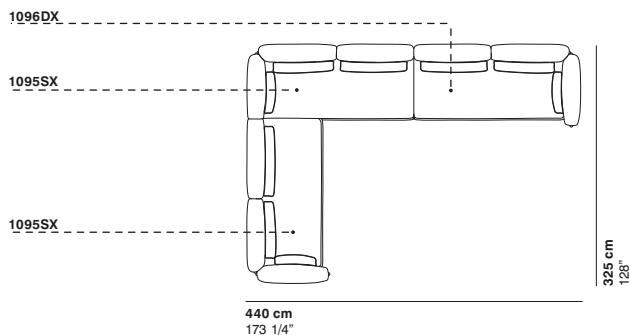

La Cividina s.r.l., al fine di migliorare le caratteristiche tecniche e qualitative della sua produzione, si riserva di apportare, anche senza preavviso, tutte le modifiche che si rendessero necessarie.

With a view to improving the technical characteristics and quality of its products la Cividina s.r.l. reserves the right to develop its products at anytime without notice.

A fin d'améliorer les caractéristiques de sa production, La Cividina s.r.l. se réserve d'apporter, même sans préavis, toutes les modifications qui se rendent nécessaires.

Zur Verbesserung, der technischen und qualitativen Merkmale, behält sich La Cividina s.r.l. vor, alle notwendigen Produktionsänderungen, auch ohne Vorankündigung durchzuführen.

LA CIVIDINA S.R.L.

HEADQUARTERS / PRODUCTION

Via Spilimbergo 162
33035 Martignacco
Udine Italy
T +39 0432 677433
F +39 0432 677480
info@lacividina.com
lacividina.com

ISO 9001



SHOWROOM MARTIGNACCO

Via Lungolavia 1
33035 Martignacco
Udine Italy
T +39 0432 677433

SHOWROOM MILANO

Palazzo Borromeo
Via Manzoni 41
20121 Milano
Italy
T +39 345 8350810