

# LOC

---

Collection

---

Filinea

Nap

Suiseki

Keisho

U

+5

laCividina

---

# Collection

---

Filinea    ARMCHAIR

---

Nap    ARMCHAIR / SOFA / DORMEUSE / OTTOMAN / SYSTEM

---

Suiseki    ARMCHAIR / SOFA / DORMEUSE / OTTOMAN / SYSTEM

---

Keisho    COFFEE TABLE

---

U    COFFEE TABLE

---



FILINEA cod. 1113  
Armchair

# Filinea

<b>Family</b>	Armchair
<b>Designer</b>	Antonino Sciortino / 2019
<b>Link</b>	<a href="http://www.read-mo.re/filinea">www.read-mo.re/filinea</a>

**IT** Dall'incontro tra natura e tecnologia è nata Filinea, una poltrona futuristica ispirata all'*euphorbia tirucalli* e realizzata in sottilissimo tondino d'acciaio. Le complesse ramificazioni di questa pianta, molto diffusa in Sud Italia, sono state lo spunto di un progetto impossibile: una sagoma d'aria costituita da linee geometriche che s'intersecano tra loro per creare una poltrona. Una seduta leggerissima realizzata da mani esperte con un tondino d'acciaio spesso soltanto pochi millimetri. Un ordinato groviglio sul quale riposare come sospesi in aria.

**EN** The futuristic Filinea armchair fuses natural and technological qualities. It takes its cue from *euphorbia tirucalli* trees and is made of round, extremely slender steel bars. The plants are very common in the South of Italy and their intricately arrayed branches inspired a seemingly impossible design: intersecting geometric lines that create an armchair with an airy outline. The extremely light seat is made by expert hands from round steel bars that are just a few millimeters thick. It feels like you are floating in the air when you sit on the tangled yet tidy framework.

**FR** Filinea, un fauteuil futuriste inspiré de l'*euphorbia tirucalli* et réalisé à partir d'une tige d'acier très fine, est né de la rencontre entre la nature et la technologie. Les ramifications complexes de cette plante, très répandue dans le sud de l'Italie, ont été le point de départ d'un projet impossible : une silhouette aérienne composée de lignes géométriques qui se croisent pour créer un fauteuil. Un siège ultra léger réalisé par des mains expertes avec une tige d'acier de seulement quelques millimètres d'épaisseur. Un enchevêtrement ordonné sur lequel il fait bon se reposer avec la sensation d'être suspendus dans l'air.

**DE** Natur und Technologie standen gemeinsam Pate bei Filinea, einem futuristischen Sessel, der von dem „Bleistiftstrauch“ *Euphorbia tirucalli* inspiriert und aus hauchdünnen Stahlstäben gefertigt wird. Die komplexe Verästelung dieser Pflanze, die in Süditalien sehr verbreitet ist, war der Ausgangspunkt für ein außergewöhnliches Projekt: eine luftige Silhouette aus geometrischen Linien, die sich überschneiden und einen Sessel entstehen lassen. Das federleichte Sitzmöbel wird von erfahrenen Händen aus Rundstahl in einer Stärke von wenigen Millimetern hergestellt. Ein geordnetes Knäuel, auf dem man sich schwebend erholen kann.



**FILINEA** cod. 1113  
Armchair /  
**FILINEA** cod. 10035  
Cushion



**FILINEA** cod. 1113  
Armchair /  
**NAP** cod. 1096DX  
Right element 220 with cushions





**FILINEA** cod. 1113  
Armchair

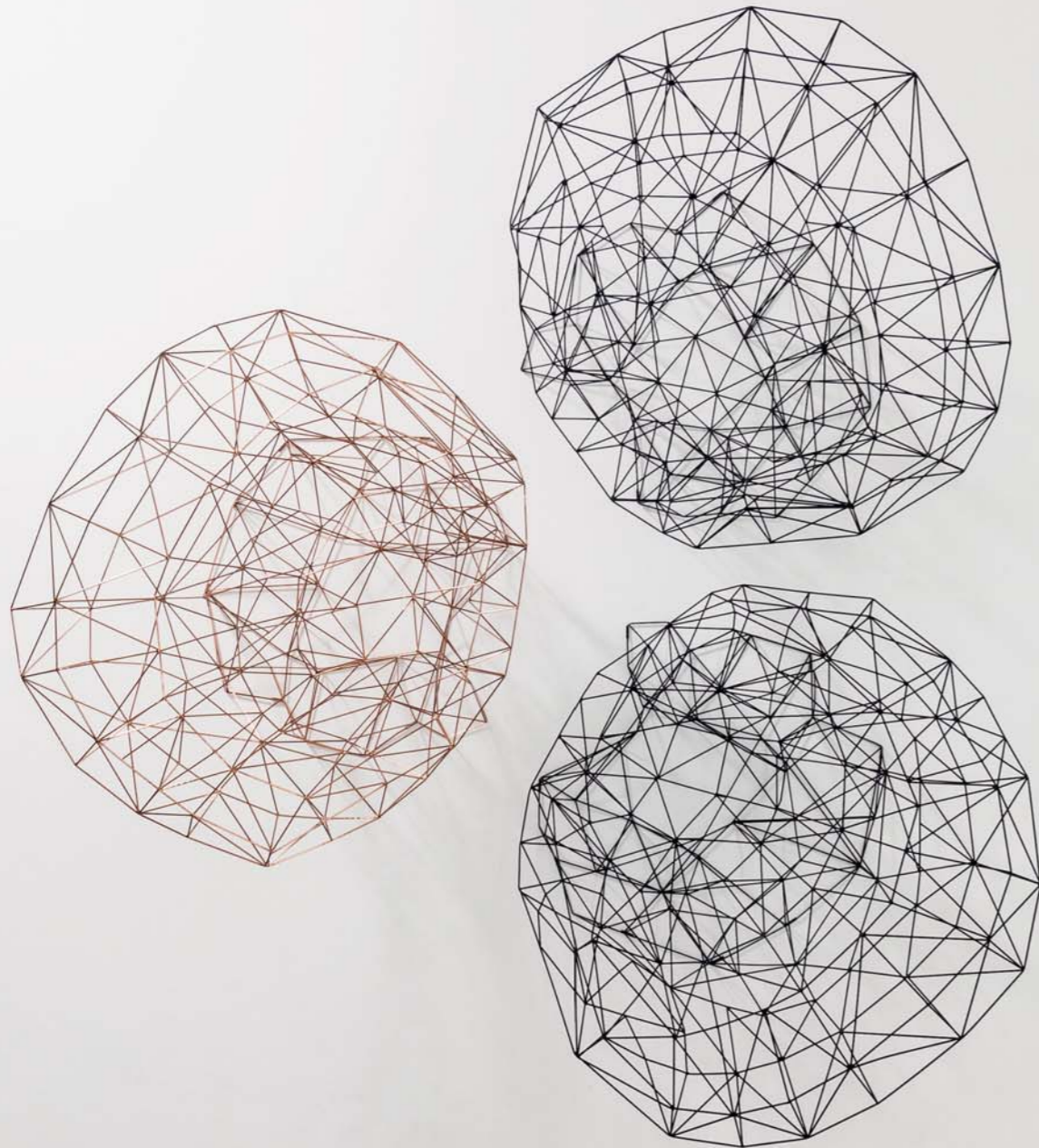

**FILINEA** cod. 1113  
Armchair /  
**FILINEA** cod. 10035  
Cushion

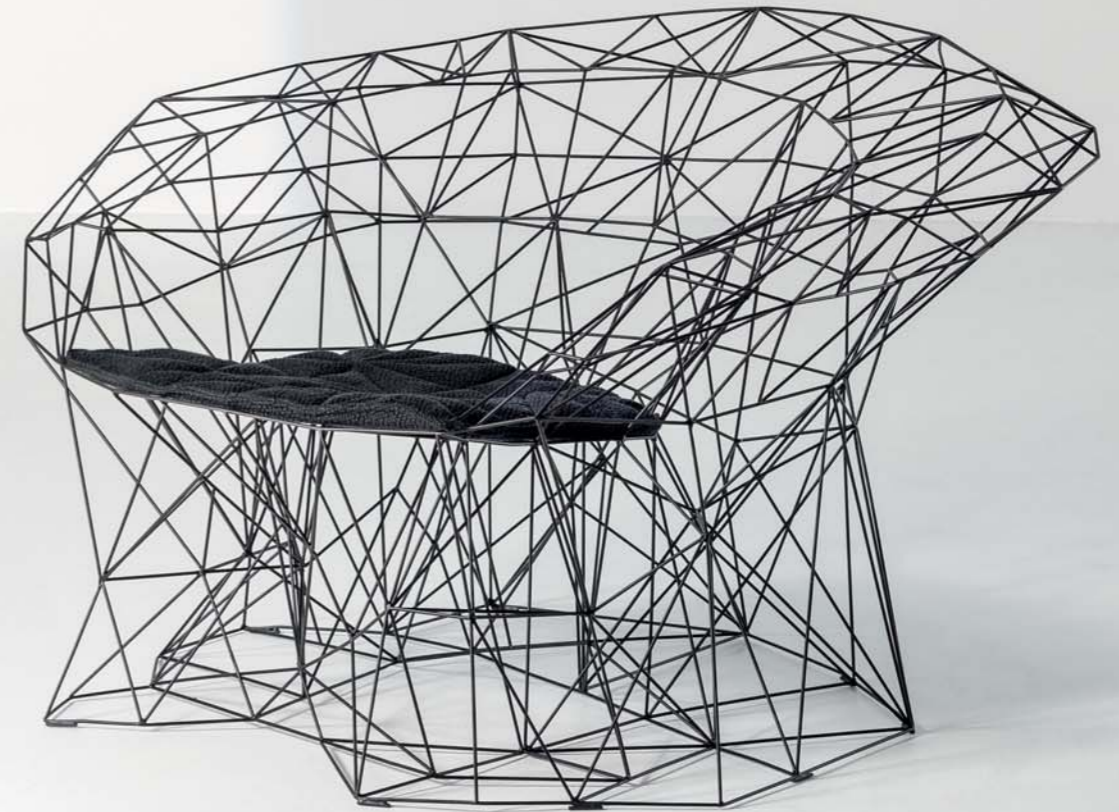



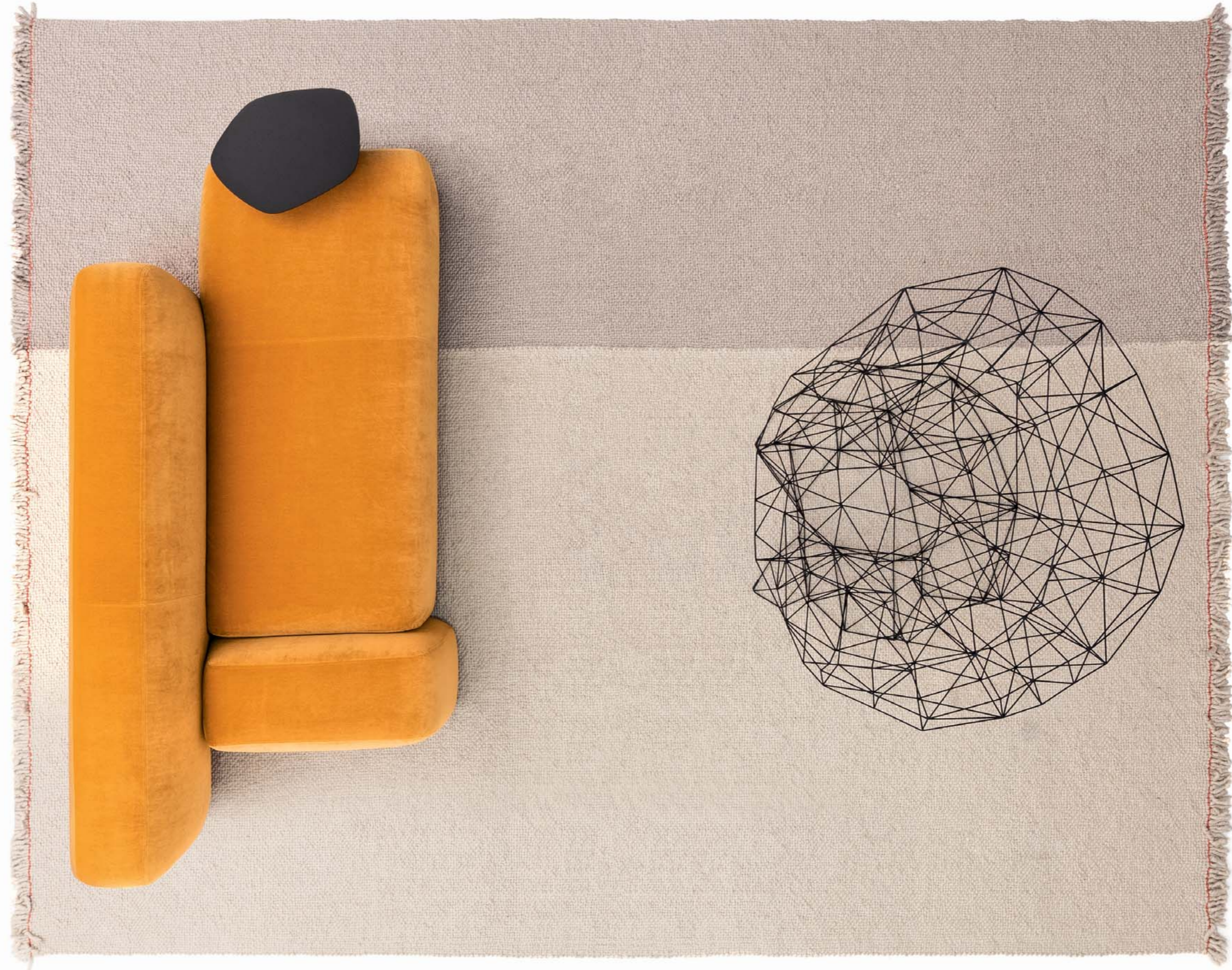

**FILINEA** cod. 1113  
Armchair /  
**SUISEKI** cod. SUI08SX  
Composition /  
**KEISHO** cod. 1110  
Coffee table



Dati tecnici · Technical data · Données techniques · Technische Angaben

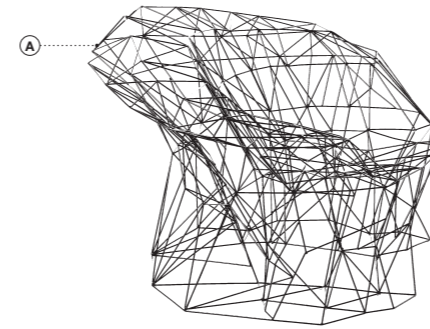

- A. Acciaio
- A. Steel
- A. Acier
- A. Stahl

Caratteristiche · Features · Caractéristiques · Eigenheiten

- Telaio rinforzato per uso aree pubbliche
- Reinforced frame for public area use
- Structure renforcée pour une utilisation en espace public
- Verstärkte Holzstruktur für Nutzung bei öffentlichem Bereich

Coordinati · Matching items · Produits assortis · Abgestimmte Produkte



BOLD



DUOTONE

Finiture · Finishes · Finitions · Ausführungen



Rame  
Copper  
Cuivre  
Kupfer



Prugna  
Plum  
Prune  
Pflaume



Nero pece  
Pitch black  
Poix noir  
Pech Schwarz

cod. 1113 / armchair

cod. 10035 / cushion

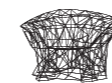

130 cm  
51 1/8"



110 cm  
43 1/4"

77 cm  
30 3/8"

41 cm  
16 1/8"



60 cm  
23 5/8"

60 cm  
23 5/8"

3 cm  
1 1/8"





NAP cod. 1097SX  
Left dormeuse with cushions

## Nap

<b>Family</b>	Armchair / Sofa / Dormeuse / Ottoman / System
<b>Designer</b>	Andrea Steidl / 2019
<b>Link</b>	<a href="http://www.read-mo.re/nap">www.read-mo.re/nap</a>

**IT** Una seduta morbida e composta, che allude al riposo nel nome e nella forma. Nap è una reinterpretazione del guanciale in versione maxi e in ottica sartoriale, con cuciture studiate per accrescerne l'aspetto pieno – come il pipe che delimita i cuscini e le pinces orizzontali. Elemento di comfort in più, il cuscino poggiatesta: fissato allo schienale con una zip invisibile, assicura al divano la giusta compostezza, nelle situazioni del contract così come negli ambienti residenziali. Completano la struttura i piedini in legno di frassino naturale o tinto dal design minimale, che quasi scompaiono sotto la ricca seduta.

**EN** Both the name and the shape of this soft, smart seat evoke the idea of restfulness. Nap takes the idea of a pillow and recreates it in an extra-large, sartorial form, with seams that are designed to give it even more of a packed appearance, such as piping around the edges of the cushions and horizontal darts. Extra comfort is added by the lumbar support cushion, which is attached to the backrest by a concealed zip. It gives the sofa a tidy appearance that is ideal for both the contract market and household settings. Rounding off the structure are ash feet, which are available both painted and in the natural colour of the wood. They feature a minimalist design and almost entirely disappear from view under the sumptuous seat.

**FR** Une assise douce et bien structurée, dont le nom et la forme évoquent le repos. Nap est une réinterprétation de l'oreiller en version maxi et dans une optique « sur mesure », avec des coutures conçues pour mettre en valeur les volumes – comme le passepoil qui délimite les coussins et les pinces horizontales. Élément de confort supplémentaire, le coussin de soutien lombaire : fixé au dossier par une fermeture éclair invisible, il assure une parfaite ergonomie du canapé, aussi bien en situation professionnelle qu'en milieu résidentiel. La structure est complétée par des pieds en frêne naturel ou teinté au design minimaliste, qui disparaissent pratiquement sous le siège généreux.

**DE** Ein weiches und kompaktes Sitzmöbel, dessen Name und Form auf ein Nickerchen anspielen. Nap ist eine Neuinterpretation des Kissens in einer Maxi-Ausführung mit Details, die der Schneiderkunst entlehnt sind: Die Nähte betonen das voluminöse Erscheinungsbild – wie die Paspelierung an den Kanten der Kissen und die waagrechten Abnäher. Ein weiteres komfortables Element ist das Lendenstützkissen: Es ist mit einem unsichtbaren Reißverschluss an der Rücklehne angebracht und gibt dem Sofa sowohl in den Contractbereichen als auch in Wohnräumen den richtigen Halt. Füße aus naturfarbenem oder gefärbtem Eschenholz mit minimalistischem Design, die fast unter der großzügigen Sitzfläche verschwinden, ergänzen das Gestell.



**NAP** cod. NAP03SX-C  
Composition with cushions /  
**KEISHO** cod. 1110  
Coffee table /  
**TURI TURI** cod. 8770\_D30  
/ 8772\_D40 / 8773\_D50  
Coffee table







NAP cod. 1077SX  
Left dormeuse

NAP cod. NAP03SX-C  
Composition with cushions







NAP cod. NAP03SX-C  
Composition with cushions



NAP cod. NAP03SX  
Composition



NAP cod. NAP03SX-C  
Composition with cushions



NAP cod. NAP03SX  
Composition





**NAP** cod. NAP03SX-C  
 Composition with cushions /  
**ALA** cod. 8890\_steel  
 Small armchair /  
**TURI TURI** cod. 8770\_D30  
 / 8772\_D40 / 8773\_D50  
 Coffee table



**NAP** cod. 1074  
4 seater sofa /  
**ACCURSIO** cod. 9030 / 9033  
Coffee table /  
**SCANCARÒ** cod. 8834  
Coffee table







NAP cod. 1074  
4 seater sofa



NAP cod. 1074  
4 seater sofa



NAP cod. 1074  
4 seater sofa /  
KEISHO cod. 1110  
Coffee table



**NAP** cod. 1094  
4 seater sofa with cushions



**Dati tecnici · Technical data · Données techniques · Technische Angaben**

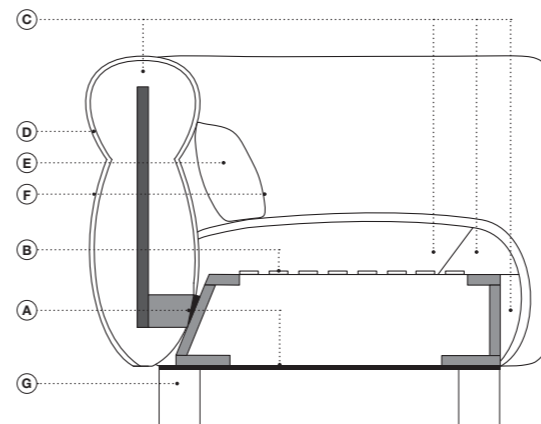

- |  |   |
|--|---|
| ■ Legno massiccio di faggio                                  | ■ Solid beech   |
| ■ Multistrato di faggio                                      | ■ Multilayered beech  |
| <b>A.</b> Acciaio  | <b>A.</b> Steel   |
| <b>B.</b> Cinghie elastiche ad alta densità                  | <b>B.</b> High density elastic straps   |
| <b>C.</b> Poliuretano espanso ignifugo a quote differenziate | <b>C.</b> Flame-retardant undeformable polyurethane foam of different densities |
| <b>D.</b> Fibra di poliestere                                | <b>D.</b> Polyester fibers  |
| <b>E.</b> Piuma e fibra di poliestere elicoidale             | <b>E.</b> Feathers and helical polyester fibers                                 |
| <b>F.</b> Rivestimento                                       | <b>F.</b> Upholstery  |
| <b>G.</b> Legno di frassino                                  | <b>G.</b> Ash wood  |
- 
- |  |  |
|--|--|
| ■ Bois de hêtre massif   | ■ Massivholz aus Buche   |
| ■ Multiplis de hêtre   | ■ Buchenschichtholz  |
| <b>A.</b> Acier  | <b>A.</b> Stahl  |
| <b>B.</b> Sangles élastiques   | <b>B.</b> Elastischen Gurtbändern  |
| <b>C.</b> Mousse polyuréthane expansé ignifuge indéformable à épaisseurs différenciées | <b>C.</b> Feuerfester formbeständige Polyurethanschaum in unterschiedlicher Dichte |
| <b>D.</b> Fibre de polyester   | <b>D.</b> Polyester  |
| <b>E.</b> Plume et fibre de polyester hélicoïdal                                       | <b>E.</b> Daunen und Polyesterfaser spiralförmig                                   |
| <b>F.</b> Revêtement   | <b>F.</b> Bezug  |
| <b>G.</b> Bois de frêne  | <b>G.</b> Eschenholz   |

**Caratteristiche · Features · Caractéristiques · Eigenheiten**

- |   |   |   |  |
|---|---|---|--|
| · Telaio rinforzato per uso aree pubbliche                                | · Reinforced frame for public area use                  | · Structure renforcée pour une utilisation en espace public           | · Verstärkte Holzstruktur für Nutzung bei öffentlichem Bereich |
| · Poliuretano espanso ignifugo  | · Flame-retardant polyurethane foam                     | · Mousse polyuréthane expansé ignifuge                                | · Feuerfester Polyurethanschaum                                |
| · Poliuretano espanso indeformabile a quote differenziate ad alta densità | · Undeformable polyurethane foam of different densities | · Mousse polyuréthane expansé indéformable à épaisseurs différenciées | · Formbeständige Polyurethanschaum in unterschiedlicher Dichte |
| · Cuciture rinforzate con supporto in fibra di carbonio                   | · Reinforced stitching with carbon fiber support        | · Coutures renforcées de fibre de carbone                             | · Verstärkte Säume mit Stütz aus Kohlefaser                    |
| · La collezione è sfoderabile nella versione in tessuto                   | · Covers are removable in fabric version                | · La collection est déhoussable dans la version en tissu              | · Die Kollektion ist in der Stoffversion abziehbar             |

**Coordinati · Matching items · Produits assortis · Abgestimmte Produkte**



**Finitura piedi · Legs finishes · Finition de pieds · Füße Ausführungen**

- |  |   |
|--|---|
|  |   |
| Frassino naturale<br>Natural ash<br>Frêne naturel<br>Eschenholz Naturfarbe | Frassino tinto grafite<br>Graphite-stained ash<br>Frêne teinté graphite<br>Eschenholz Graphit gebeizt |



cod. 1070 / armchair

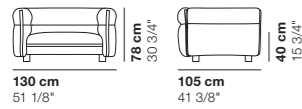

cod. 1071 / 2 seater sofa

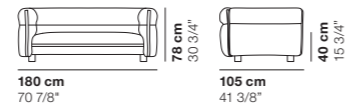

cod. 1072 / 3 seater sofa

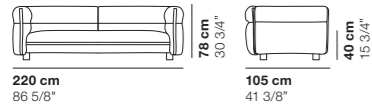

cod. 1073 / 3 seater sofa major

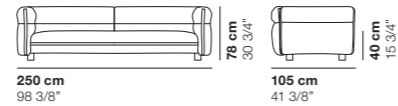

cod. 1074 / 4 seater sofa

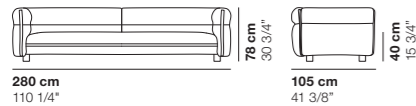

cod. 1075SX / left element 220

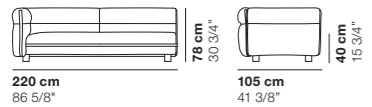

cod. 1076DX / right element 220

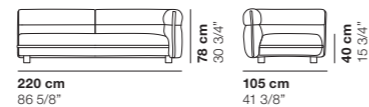

cod. 1077SX / left dormeuse

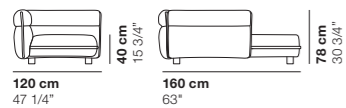

cod. 1078DX / right dormeuse

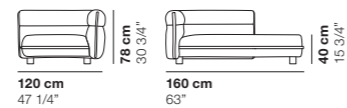

cod. 1079 / ottoman 100

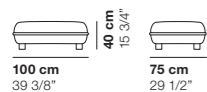

cod. 1080 / ottoman 140

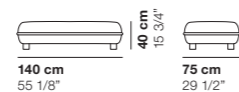

cod. NAP01 / composition

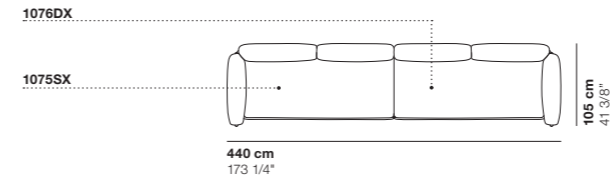

cod. NAP02DX / composition

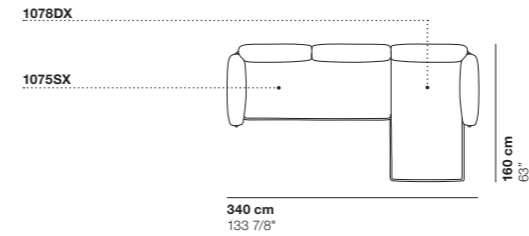

cod. NAP03SX / composition

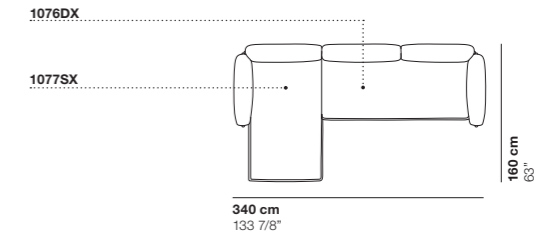

cod. NAP04 / composition

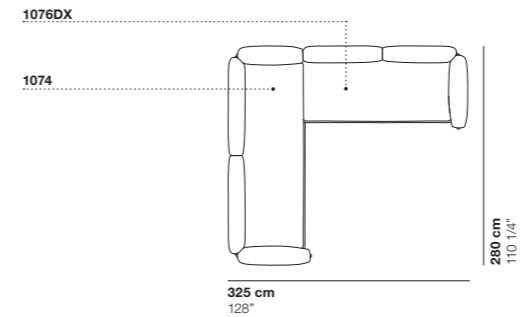

cod. NAP05 / composition

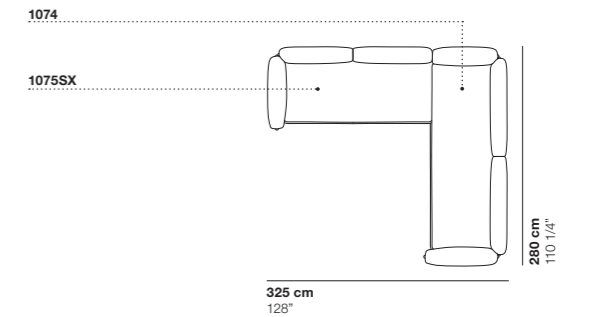

cod. NAP06 / composition

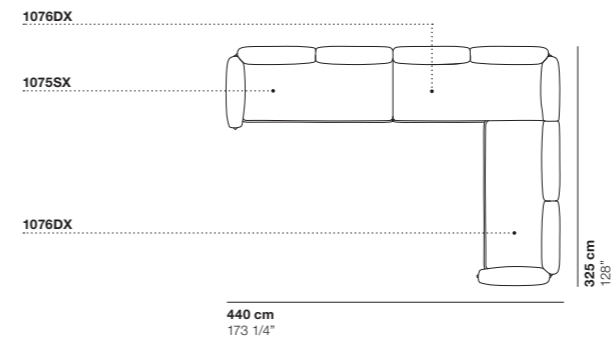

cod. NAP07 / composition

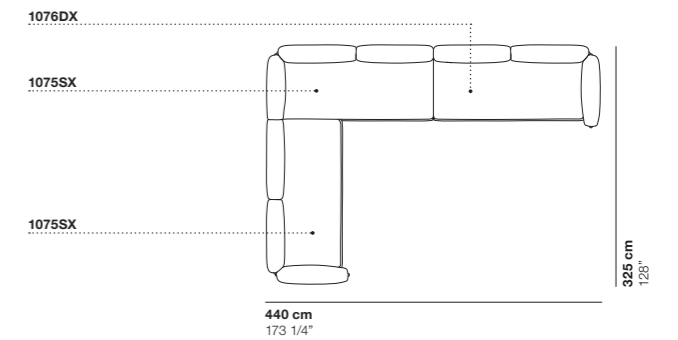



cod. 1090 / armchair with cushions

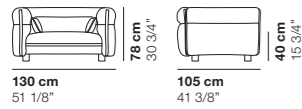

cod. 1091 / 2 seater sofa with cushions

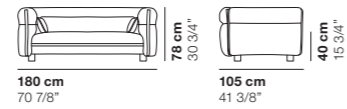

cod. 1092 / 3 seater sofa with cushions



cod. 1093 / 3 seater sofa major with cushions

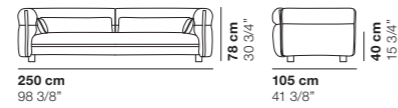

cod. 1094 / 4 seater sofa with cushions

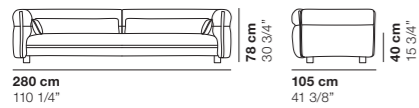

cod. 1095SX / left element 220 with cushions

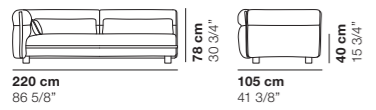

cod. 1096DX / right element 220 with cushions

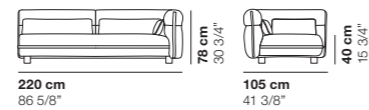

cod. 1097SX / left dormeuse with cushions

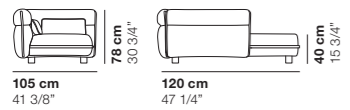

cod. 1098DX / right dormeuse with cushions

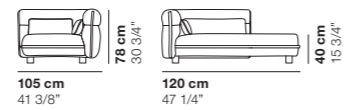

cod. NAP01-C / composition with cushions

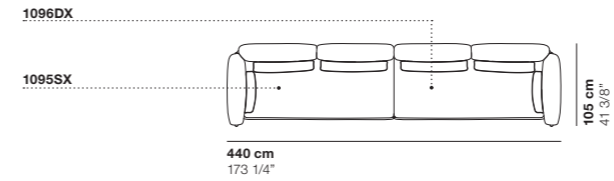

cod. NAP02DX-C / composition with cushions

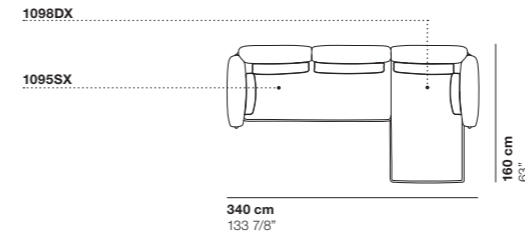

cod. NAP03SX-C / composition with cushions

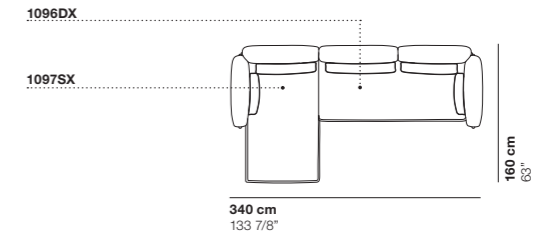

cod. NAP04-C / composition with cushions

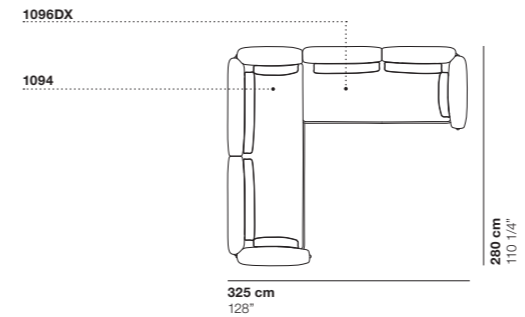

cod. NAP05-C / composition with cushions

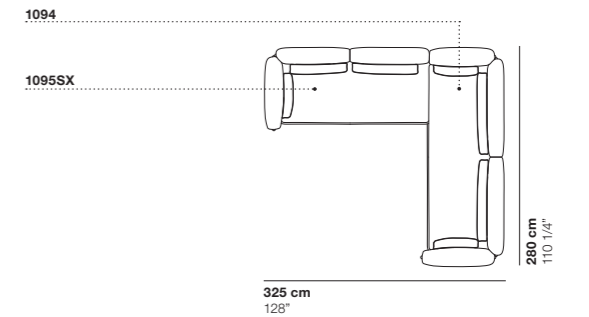

cod. NAP06-C / composition with cushions

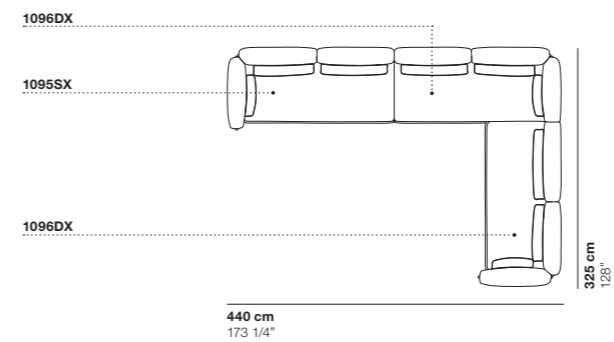

cod. NAP07-C / composition with cushions

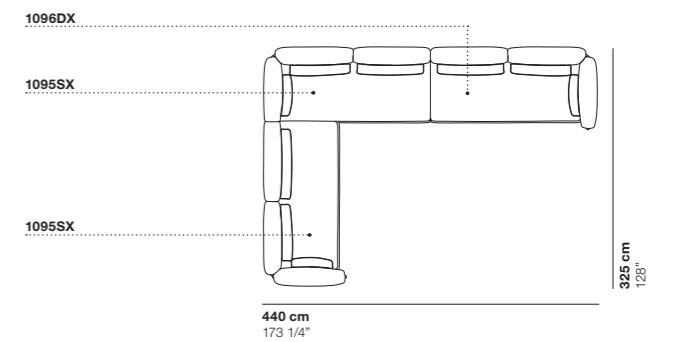



SUISEKI cod. SU16SX  
Composition



## Suiseki

### Family

Armchair / Sofa / Dormeuse / Ottoman / System

### Designer

Andrea Steidl / 2019

### Link

[www.read-mo.re/suiseki](http://www.read-mo.re/suiseki)

**IT** Suiseki è una collezione di sedute imbottite ispirate, come suggerisce il nome, all'arte giapponese di disporre le pietre trovate in natura. Moduli essenziali dalle volumetrie organiche, dove la geometria lascia spazio a spontanei e armoniosi disallineamenti. Tre gli elementi di partenza: il sedile, basso e ampio, lo schienale e il bracciolo, da combinare tra loro in un equilibrio sfalsato di altezze, larghezze e profondità. Nascono così divani-scultura che rispondono a ogni tipologia d'impiego, dagli spazi del contract a quelli domestici.

### EN

Suiseki is a collection of padded seats inspired – as its name suggests – by the Japanese art of arranging naturally occurring stones. Spontaneous, harmonious lack of alignment takes the place of geometric shapes in the simple modular units with organic volumes. Everything starts with three core building blocks: a low, broad seat, a backrest and an armrest. They can be combined with each other in an offset display of heights, widths and depths. The resulting sofas are sculptural and suitable for all types of use, in everything from the contract market to private homes.

### FR

Suiseki est une collection d'assises rembourrées inspirées, comme son nom l'indique, de l'art japonais d'arranger les pierres trouvées dans la nature. Des modules essentiels aux volumes organiques, où la géométrie se prête à des décalages spontanés et harmonieux. Elle est formée de trois éléments de départ : l'assise basse et large, le dossier et l'accoudoir, à combiner en un équilibre décalé de hauteurs, largeurs et profondeurs. C'est ainsi que naissent ces canapés-sculptures, capables de s'adapter à tous les types d'utilisation, pour les espaces professionnels comme pour ceux résidentiels.

### DE

Suiseki ist eine Kollektion mit Polstermöbeln, die – wie schon der Name sagt – von der japanischen Kunst der Präsentation natürlicher Steine inspiriert wurden. Essenzielle Module mit organischen Formen, deren Geometrie Raum für spontane und harmonische Verlagerungen lässt. Die Ausgangselemente sind drei: ein niedriger und breiter Sitz, Rückenlehne und Armstütze, die miteinander in einem versetzten Gleichgewicht der Höhen, Breiten und Tiefen kombiniert werden. So entstehen skulpturartige Sofas, die in jedem Kontext Einsatz finden – vom Contractbereich bis zu häuslichen Räumlichkeiten.



**SUISEKI** cod. SUI16SX  
Composition /  
**KEISHO** cod. 1110  
Coffee table /  
**ACCURSIO** cod. 9037 / 9042  
Coffee table







**SUISEKI** cod. SUI16SX  
 Composition /  
**DEP** cod. 8401  
 Small armchair /  
**KEISHO** cod. 1110  
 Coffee table /  
**SCANCARÒ** cod. 8830  
 Coffee table /  
**ACCURSIO** cod. 9042  
 Coffee table



**SUISEKI** cod. 1069SX  
Left armchair /  
**SUISEKI** cod. SUI07DX  
Composition /  
**TURI TURI** cod. 8770\_D30  
/ 8772\_D40 / 8773\_D50  
Coffee table /  
**MIL** cod. 9095  
Coffee table





**SUISEKI** cod. 1068DX  
Right armchair /  
**SUISEKI** cod. 1069SX  
Left armchair /  
**SUISEKI** cod. SUI07DX  
Composition /  
**U** cod. 1101  
Coffee table /  
**TURI TURI** cod. 8770\_D30  
Coffee table /  
**ACCURSIO** cod. 9042  
Coffee table

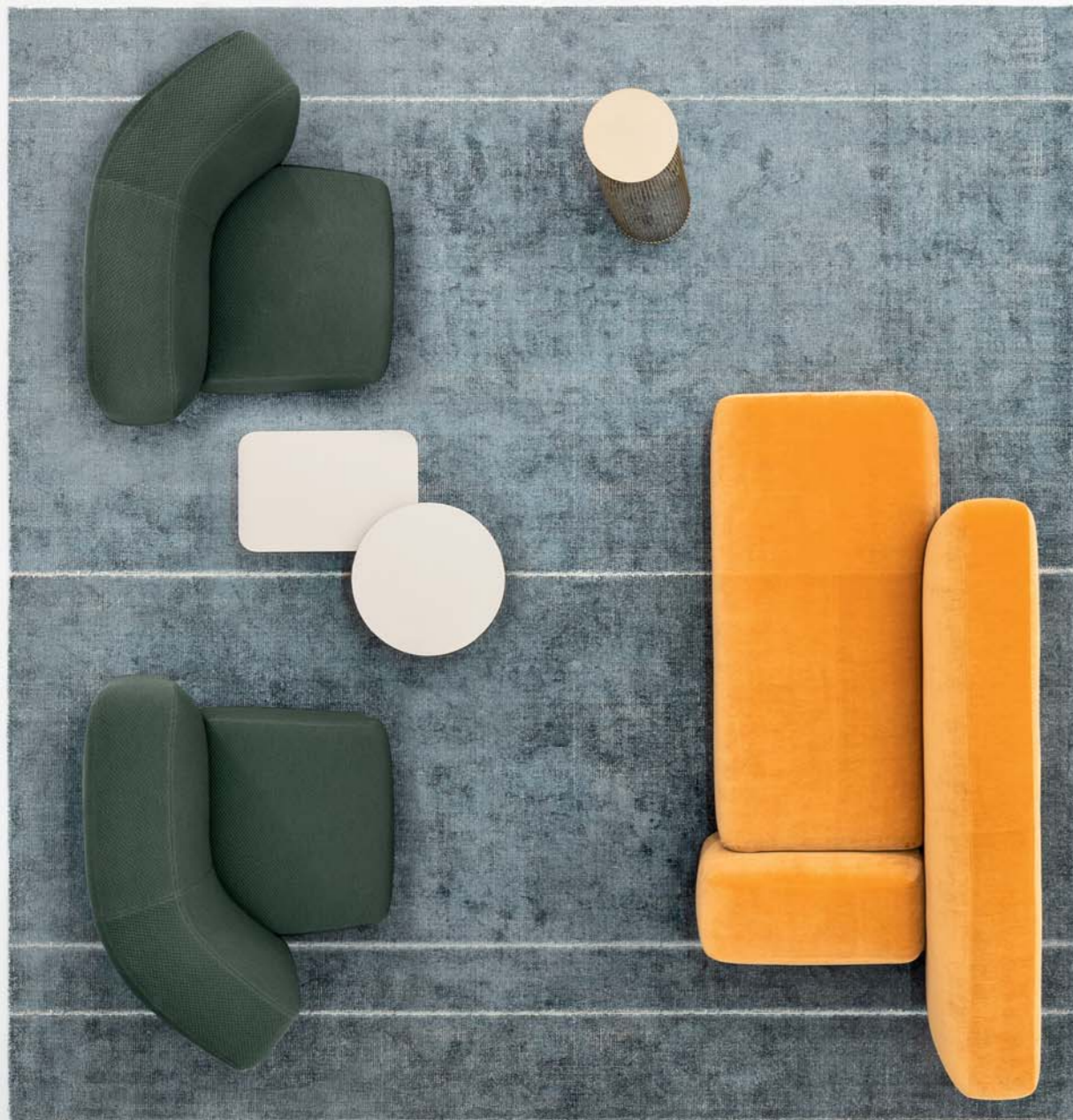

**SUISEKI** cod. 1069SX  
Left armchair /  
**SUISEKI** cod. 1068DX  
Right armchair /  
**ACCURSIO** cod. 9037  
Coffee table /  
**SCANCARÒ** cod. 8830  
Coffee table





**SUISEKI** cod. SUI06SX  
/ SUI20SX / SUI18DX / SUI01  
Composition

**SUISEKI** cod. SUI14SX  
/ SUI07SX / SUI12DX / SUI03  
Composition

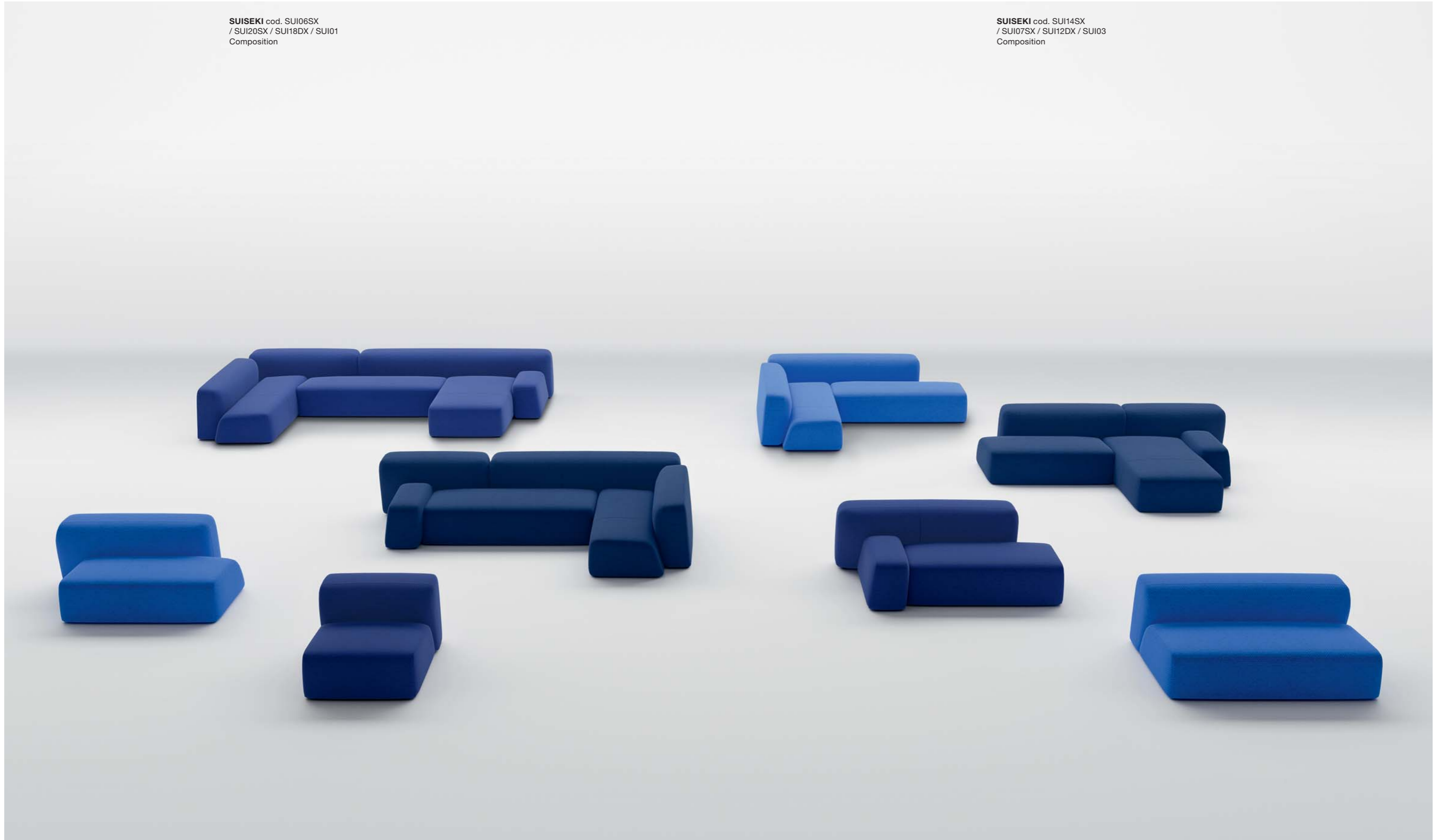



**SUISEKI** cod. SUI17SX  
/ SUI02 / SUI19DX / SUI10SX  
Composition

**SUISEKI** cod. SUI15SX  
/ SUI09DX / SUI04 / SUI11DX  
Composition





**SUISEKI** cod. SUI13SX  
Composition /  
**KEISHO** cod. 1110  
Coffee table





**SUISEKI** cod. SUI13SX  
Composition /  
**KEISHO** cod. 1110  
Coffee table /  
**FILINEA** cod. 1113  
Armchair /  
**FILINEA** cod. 10035  
Cushion





SUISEKI cod. SUI13SX  
Composition



Dati tecnici · Technical data · Données techniques · Technische Angaben

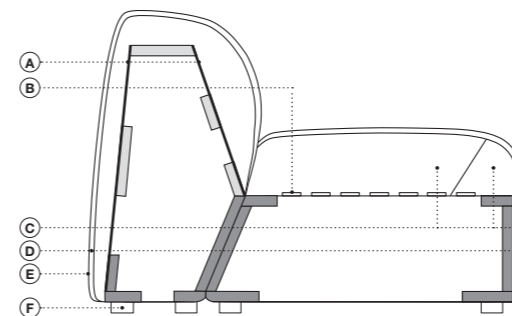

- Legno massiccio di abete
- Legno massiccio di faggio
- A. Pannello di masonite
- B. Cinghie elastiche ad alta densità
- C. Poliuretano espanso ignifugo a quote differenziate
- D. Fibra di poliestere
- E. Rivestimento
- F. Polipropilene

- Solid fir
- Solid beech
- A. Masonite panels
- B. High density elastic straps
- C. Flame-retardant undeformable polyurethane foam of different densities
- D. Polyester fibers
- E. Upholstery
- F. Polypropylene

- Bois de sapin massif
- Bois de hêtre massif
- A. Panneau de particules
- B. Sangles élastiques
- C. Mousse polyuréthane expansé ignifuge indéformable à épaisseurs différenciées
- D. Fibre de polyester
- E. Revêtement
- F. Polypropylène

- Massivholz aus Tanne
- Massivholz aus Buche
- A. Holzfaserplatte
- B. Elastischen Gurtbändern
- C. Feuerfester formbeständige Polyurethanschaum in unterschiedlicher Dichte
- D. Polyester
- E. Bezug
- F. Polypropylen

Caratteristiche · Features · Caractéristiques · Eigenheiten

- Telaio rinforzato per uso aree pubbliche
- Poliuretano espanso ignifugo
- Poliuretano espanso indeformabile a quote differenziate ad alta densità
- Cuciture rinforzate con supporto in fibra di carbonio
- Prodotto disponibile anche su misura
- La collezione è sfoderabile su richiesta nella versione in tessuto

- Reinforced frame for public area use
- Flame-retardant polyurethane foam
- Undeformable polyurethane foam of different densities
- Reinforced stitching with carbon fiber support
- This item can be customized
- On request covers can be removable in fabric version

- Structure renforcée pour une utilisation en espace public
- Mousse polyuréthane expansé ignifuge
- Mousse polyuréthane expansé indéformable à épaisseurs différenciées
- Coutures renforcées de fibre de carbone
- Produit pouvant être réalisés sur mesure
- La collection est déhoussable, sur demande, dans la version en tissu

- Verstärkte Holzstruktur für Nutzung bei öffentlichem Bereich
- Feuerfester Polyurethanschaum
- Formbeständige Polyurethanschaum in unterschiedlicher Dichte
- Verstärkte Säume mit Stütz aus Kohlefaser
- Produkt nach Maß verfügbar
- Die Kollektion ist auf Anfrage in der Stoffversion abziehbar

Coordinati · Matching items · Produits assortis · Abgestimmte Produkte



KEISHO



U



TURI TURI



BOLD



DUOTONE

cod. 1050 / back 100

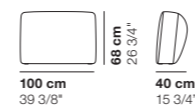

cod. 1051 / back 120

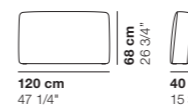

cod. 1052 / back 150

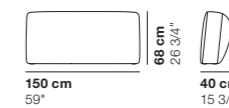

cod. 1053 / back 180

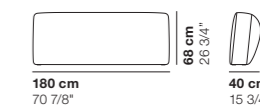

cod. 1054 / back 210

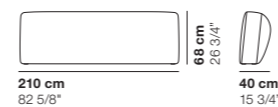

cod. 1055 / back 270

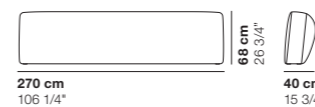

cod. 1060 / seat 100

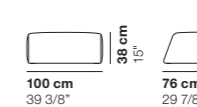

cod. 1061 / seat 150

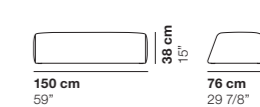



cod. 1062 / seat 180      cod. 1063 / dormeuse 90      cod. 1064 / right armrest      cod. 1065 / left armrest



cod. 1066 / ottoman 100      cod. 1067 / ottoman 150      cod. 1068DX / right armchair      cod. 1069SX / left armchair



cod. SUI01 / composition      cod. SUI02 / composition

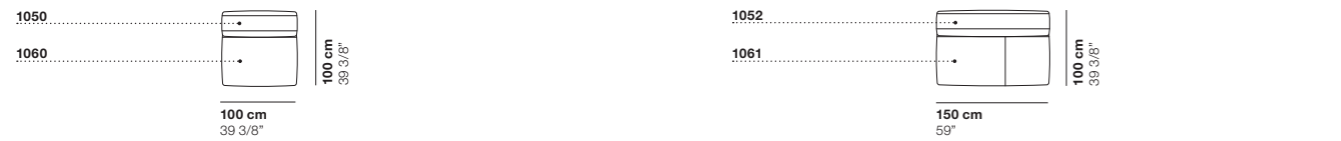

cod. SUI03 / composition      cod. SUI04 / composition

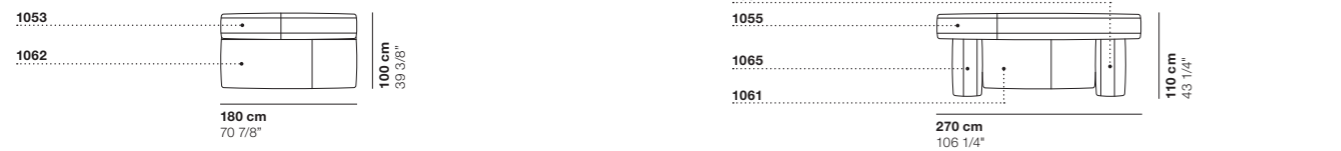

cod. SUI05 / composition

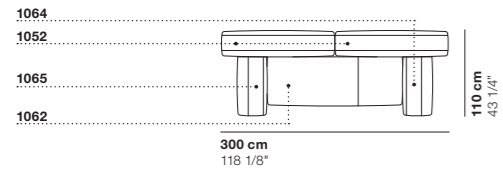

cod. SUI06SX / composition      cod. SUI06DX / composition



cod. SUI07SX / composition      cod. SUI07DX / composition



cod. SUI08SX / composition      cod. SUI08DX / composition



cod. SUI09SX / composition      cod. SUI09DX / composition



cod. SUI10SX / composition      cod. SUI10DX / composition



cod. SUI11SX / composition      cod. SUI11DX / composition



cod. SUI12SX / composition      cod. SUI12DX / composition

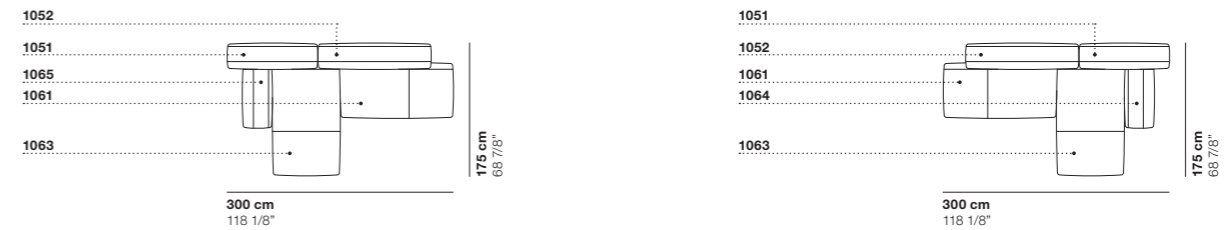



cod. SUI13SX / composition

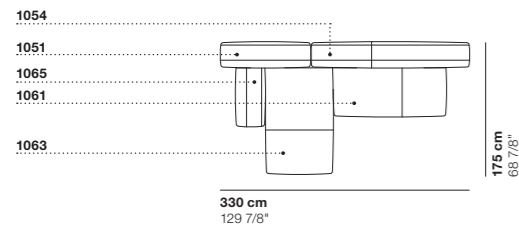

cod. SUI13DX / composition

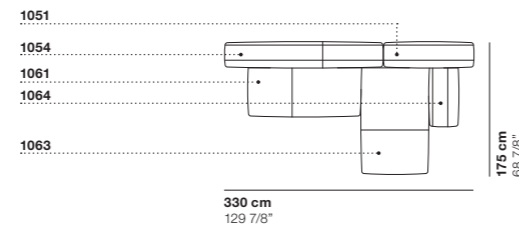

cod. SUI14SX / composition

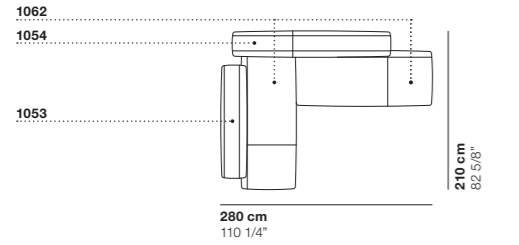

cod. SUI14DX / composition

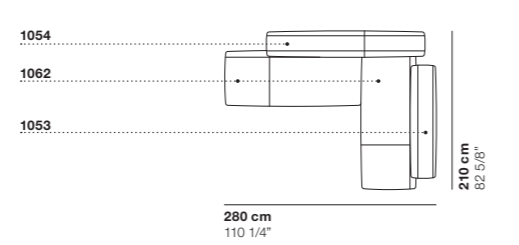

cod. SUI15SX / composition

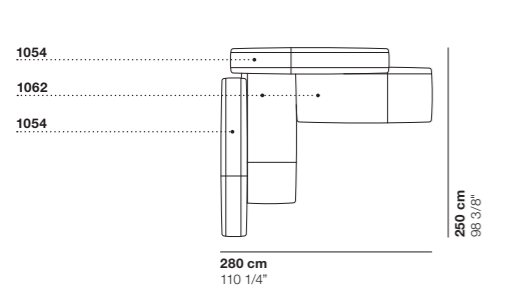

cod. SUI15DX / composition

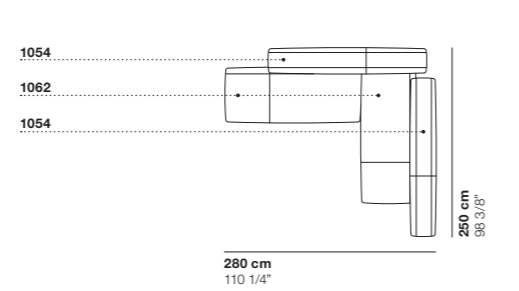

cod. SUI16SX / composition

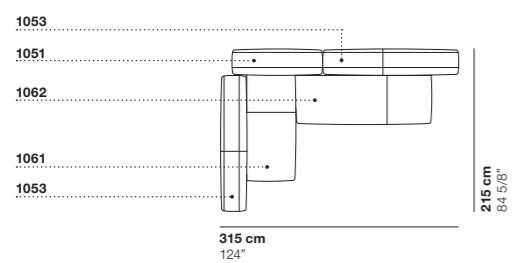

cod. SUI16DX / composition

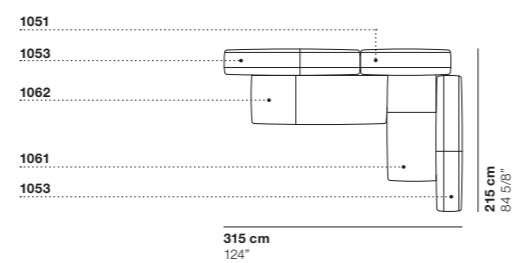

cod. SUI17SX / composition

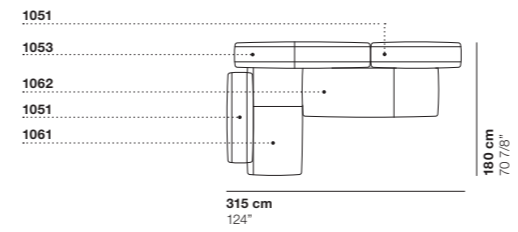

cod. SUI17DX / composition

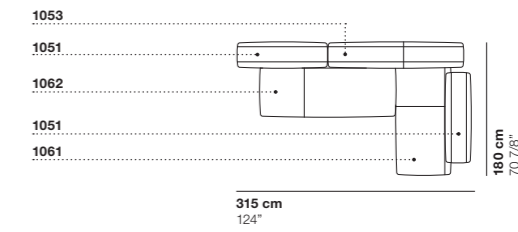

cod. SUI18SX / composition

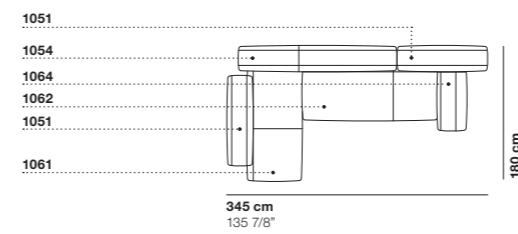

cod. SUI18DX / composition

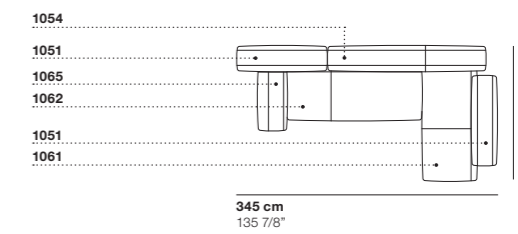

cod. SUI19SX / composition

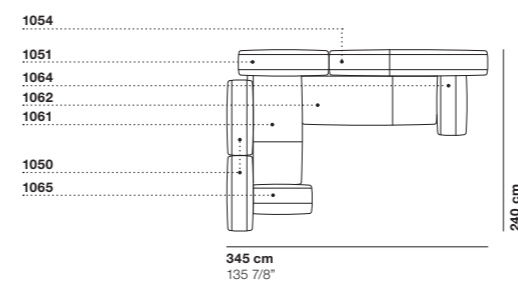

cod. SUI19DX / composition

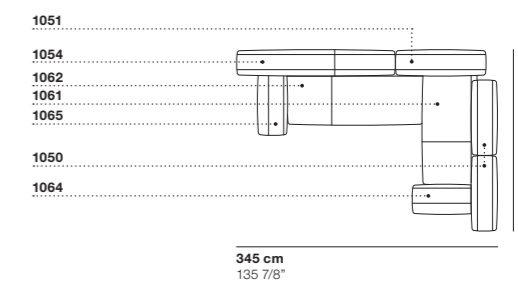

cod. SUI20SX / composition

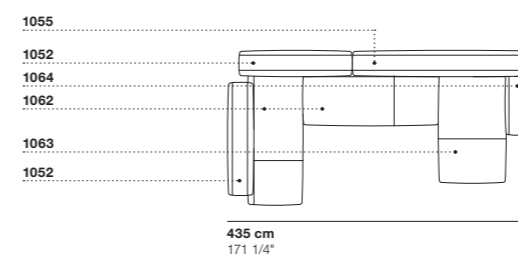

cod. SUI20DX / composition

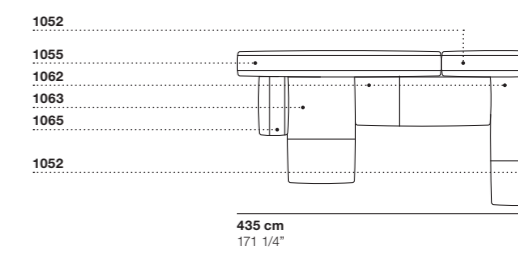



KEISHO cod. 1110  
Coffee table /  
SUISEKI cod. SUI13SX  
Composition



## Keisho

<b>Family</b>	Coffee table
<b>Designer</b>	Andrea Steidl / 2019
<b>Link</b>	<a href="http://www.read-mo.re/keisho">www.read-mo.re/keisho</a>

**IT** A forme organiche e naturali è ispirato anche Keisho, un servetto nato per completare la collezione Suseki ma evolutosi come complemento ideale per tutti i divani LaCividina. Il suo stile semplice e ricercato trova origine, come suggerisce il nome, nelle pietre che hanno assunto forme sculturali per la sola azione del tempo e degli agenti atmosferici. Leggero e facile da spostare, Keisho si avvicina al divano in qualsiasi punto, per vivere con la massima comodità gli spazi del contract e quelli di casa.

**EN** Keisho is another creation that is inspired by natural and organic forms. Originally conceived to complement the Suseki collection, this table has developed into the ideal accessory for all LaCividina sofas. As its name suggests, the origins of its simple yet sophisticated style lie in stones that time and the elements have shaped into sculptural forms. Light and easy to move, Keisho can be positioned next to any part of a sofa, making it an unbeatably practical solution for both the contract market and household use.

**FR** Keisho s'inspire lui aussi des formes organiques et naturelles. Ce meuble d'appoint, créé pour compléter la collection Suseki, a évolué et est maintenant le complément idéal de tous les canapés LaCividina. Son style à la fois simple et raffiné puise son origine, comme son nom l'indique, dans les pierres qui ont pris des formes sculpturales simplement sous l'action du temps et des agents atmosphériques. Léger et facile à déplacer, Keisho peut être accosté à n'importe quel point du canapé, pour vivre avec le maximum de confort les espaces professionnels et de la maison.

**DE** Auch bei Keisho aus der Kollektion Suseki, einem Beistelltisch, der sich aber zur idealen Ergänzung der Sofas LaCividina entwickelt hat, dienen organische und natürliche Formen als Vorbild. Sein schlichter und gleichzeitig anspruchsvoller Stil leitet sich – wie der Name verrät – von Steinen ab, die sich nur durch den Einfluss von Zeit und Witterung in Skulpturen verwandelt haben. Keisho ist leicht und einfach zu handhaben, sodass er an jedem beliebigen Punkt an das Sofa gerückt werden kann und erlaubt, die Contractbereiche und heimischen Räume mit dem größtmöglichen Komfort auszustatten.



KEISHO

**KEISHO** cod. 1110  
Coffee table /  
**NAP** cod. 1096DX  
Right element 220 with cushions



COFFEE TABLE

**KEISHO** cod. 1110  
Coffee table



**KEISHO** cod. 1110  
Coffee table



**KEISHO** cod. 1110  
Coffee table

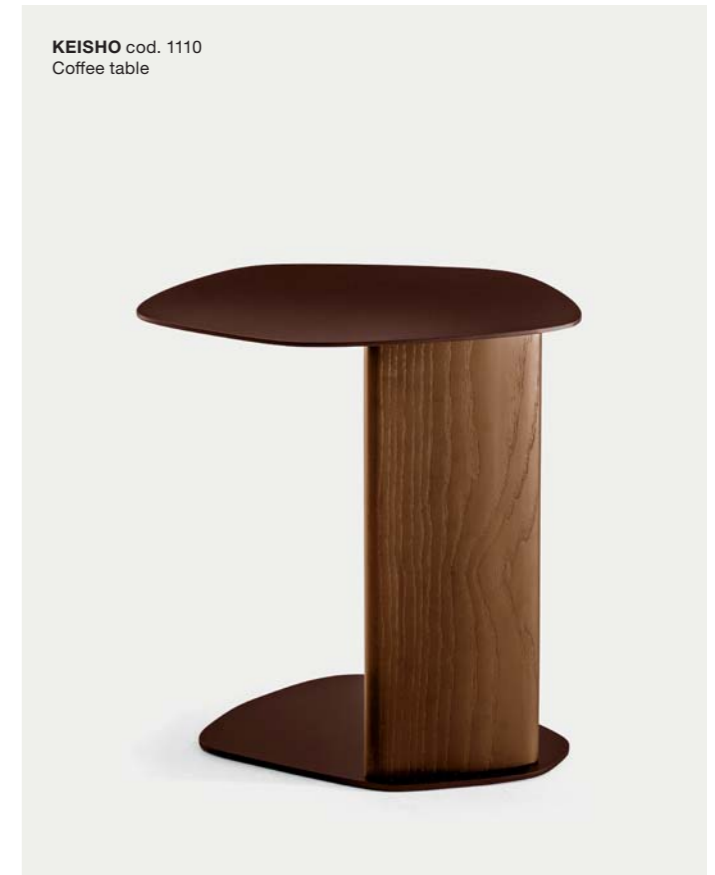



**KEISHO** cod. 1110  
Coffee table /  
**SUISEKI** cod. SUI07DX  
Composition



**KEISHO** cod. 1110  
Coffee table



**KEISHO** cod. 1110  
Coffee table /  
**SUISEKI** cod. SUI16SX  
Composition

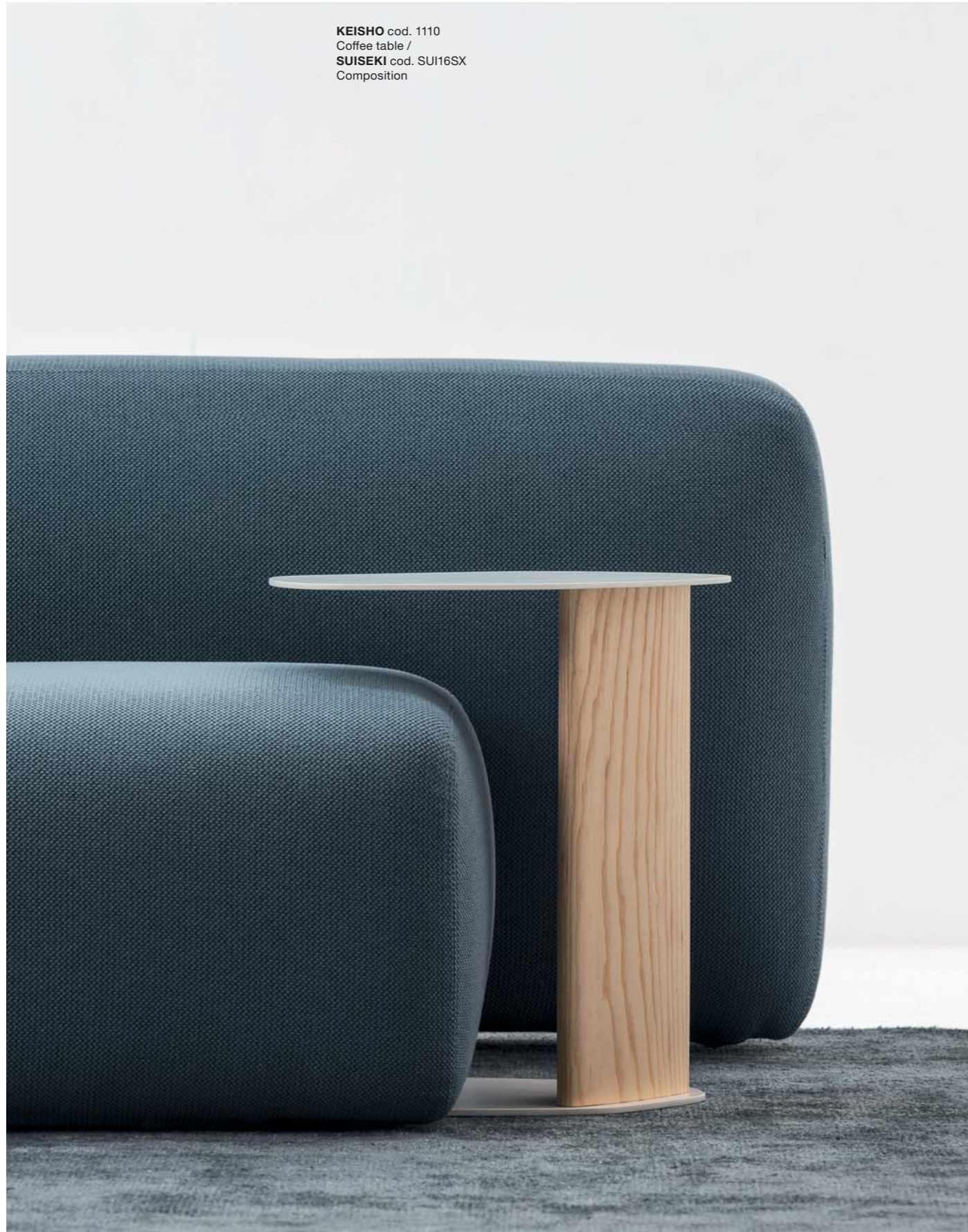

**Dati tecnici - Technical data - Données techniques - Technische Angaben**

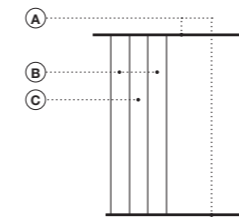

**A.** Acciaio verniciato  
**B.** Legno di frassino  
**C.** Acciaio

**A.** Lacquered steel  
**B.** Ash wood  
**C.** Steel

**A.** Acier laqué  
**B.** Bois de frêne  
**C.** Acier

**A.** Lackierter Stahl  
**B.** Eschenholz  
**C.** Stahl

**Finiture in metallo - Metal finishes - Finitions metal - Metallausführungen**



Avorio  
Ivory  
Ivoire  
Elfenbein



Fango  
Mud  
Boue  
Schlamm



Prugna  
Plum  
Prune  
Pflaume



Cioccolato  
Chocolate  
Chocolat  
Schokolade



Nero pece  
Pitch black  
Poix noir  
Pech Schwarz



Tè verde  
Green tea  
Thé vert  
Grüner Tee



Fiordaliso  
Cornflower  
Bleuet  
Kornblume



Laccato bronzo  
Lacquered bronze  
Laqué bronze  
Bronze lackiert



Laccato ottone  
Lacquered brass  
Laqué laiton  
Messing lackiert



Laccato rame  
Lacquered copper  
Laqué cuivre  
Kupfer lackiert

**Finiture in legno - Wooden finishes - Finitions bois - Holzausführungen**



Frassino naturale  
Natural ash  
Frêne naturel  
Eschenholz Naturfarbe



Frassino tinto grafite  
Graphite-stained ash  
Frêne teinté graphite  
Eschenholz Graphit gebeizt



Frassino tinto noce  
Walnut-stained ash  
Frêne teinté noyer  
Eschenholz Nussbaum gebeizt

cod. 1110 / coffee table

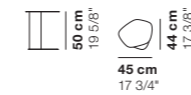



U cod. 1105  
Coffee table /  
NAP cod. 1076DX  
Right element 220



## U

<b>Family</b>	Coffee table
<b>Designer</b>	Lanzavecchia + Wai / 2019
<b>Link</b>	<a href="http://www.read-mo.re/u">www.read-mo.re/u</a>

**IT** U è una collezione di tavolini di varie dimensioni e altezze, da usare singolarmente o combinando più moduli tra loro. Segno distintivo è il sostegno a forma di U in alluminio piegato, una curva morbida che ispira anche le rotondità del piano – quadrato o rettangolare con gli angoli smussati oppure tondo. Disponibile in due versioni, in metallo o in metallo e legno, per il suo aspetto scultoreo dalle linee minimali U è ideale sia negli spazi del contract che in quelli domestici.

**EN** U is a collection of tables of various heights and sizes that can be used individually or as part of a set. Their main distinctive feature is a U-shaped support made of bent aluminium. Its soft curves inspired the rounded appearance of the tops, which come in three shapes: square or rectangular with rounded corners, and circular. There are two versions: 100% metal or metal and wood. The sculptural style with minimalist lines means that the U collection is ideal for both the contract market and private homes.

**FR** U est une collection de tables basses de différentes tailles et hauteurs, à utiliser séparément ou en combinant plusieurs modules. Elle se distingue par son support en forme de U en aluminium cintré, une courbe douce qui inspire également les rondeurs du plateau – carré ou rectangulaire avec les coins arrondis, ou encore rond. Déclinée en deux versions, métal ou métal et bois, pour son aspect sculptural aux lignes minimalistes, U est idéale pour les espaces professionnels comme résidentiels.

**DE** U ist eine Kollektion aus Tischchen in verschiedenen Größen und Höhen, die einzeln genutzt oder mit anderen Modulen kombiniert werden können. Ein charakteristisches Kennzeichen ist das u-förmige Gestell aus gebogenem Aluminium, eine weiche Kurve, die auch die runde oder die abgerundeten Ecken der quadratischen und rechteckigen Tischplatte inspiriert. Die Tische sind in zwei Versionen erhältlich – aus Metall oder Metall und Holz – und dank ihres skulpturartigen Designs mit den minimalistischen Linien in Form eines U sowohl für den Contract- als auch für den Wohnbereich geeignet.



U cod. 1101 / 1103  
Coffee table

U cod. 1106 / 1100  
Coffee table

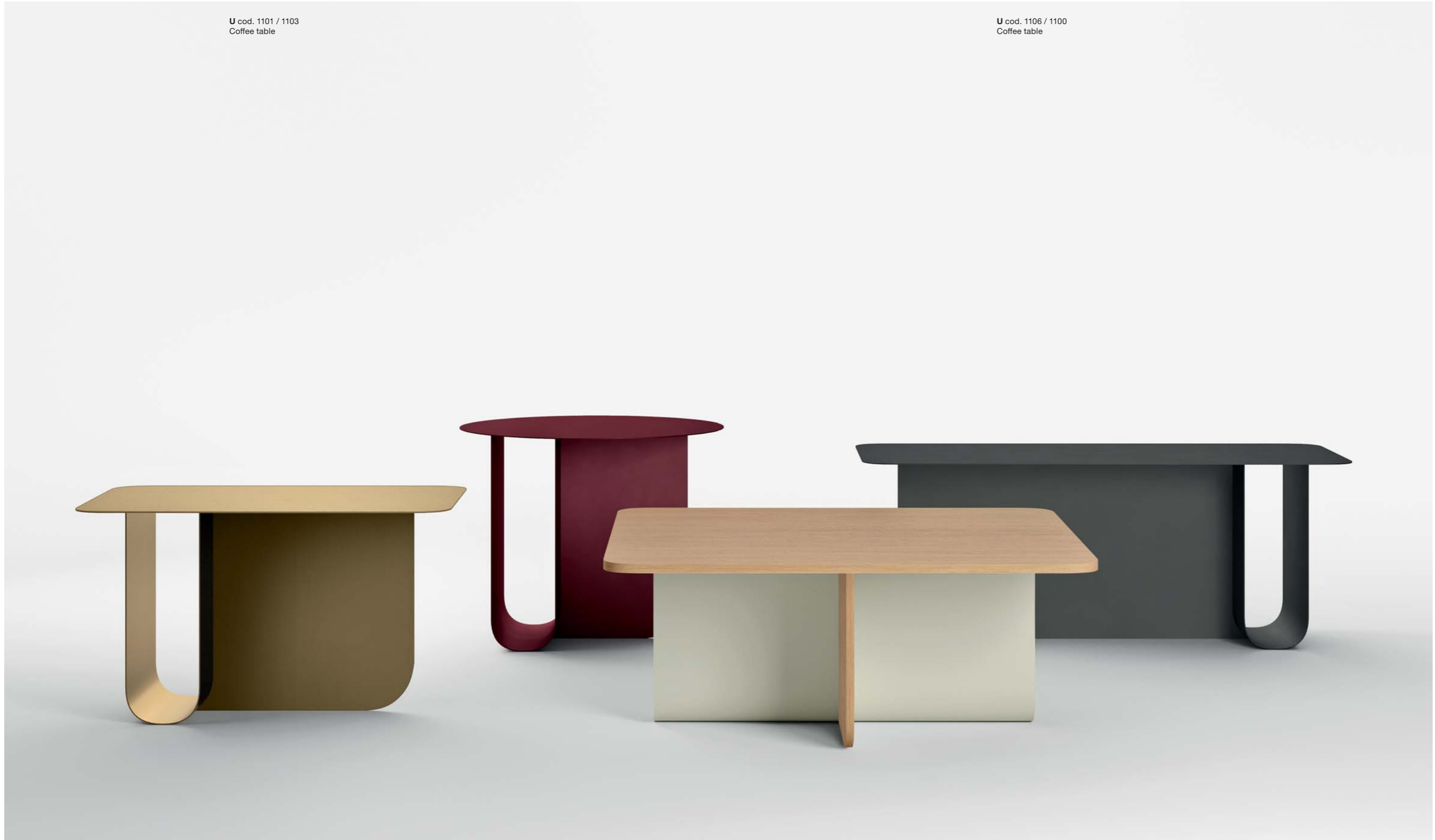



U

U cod. 1102 / 1101  
Coffee table



COFFEE TABLE

U cod. 1106 / 1103  
Coffee table





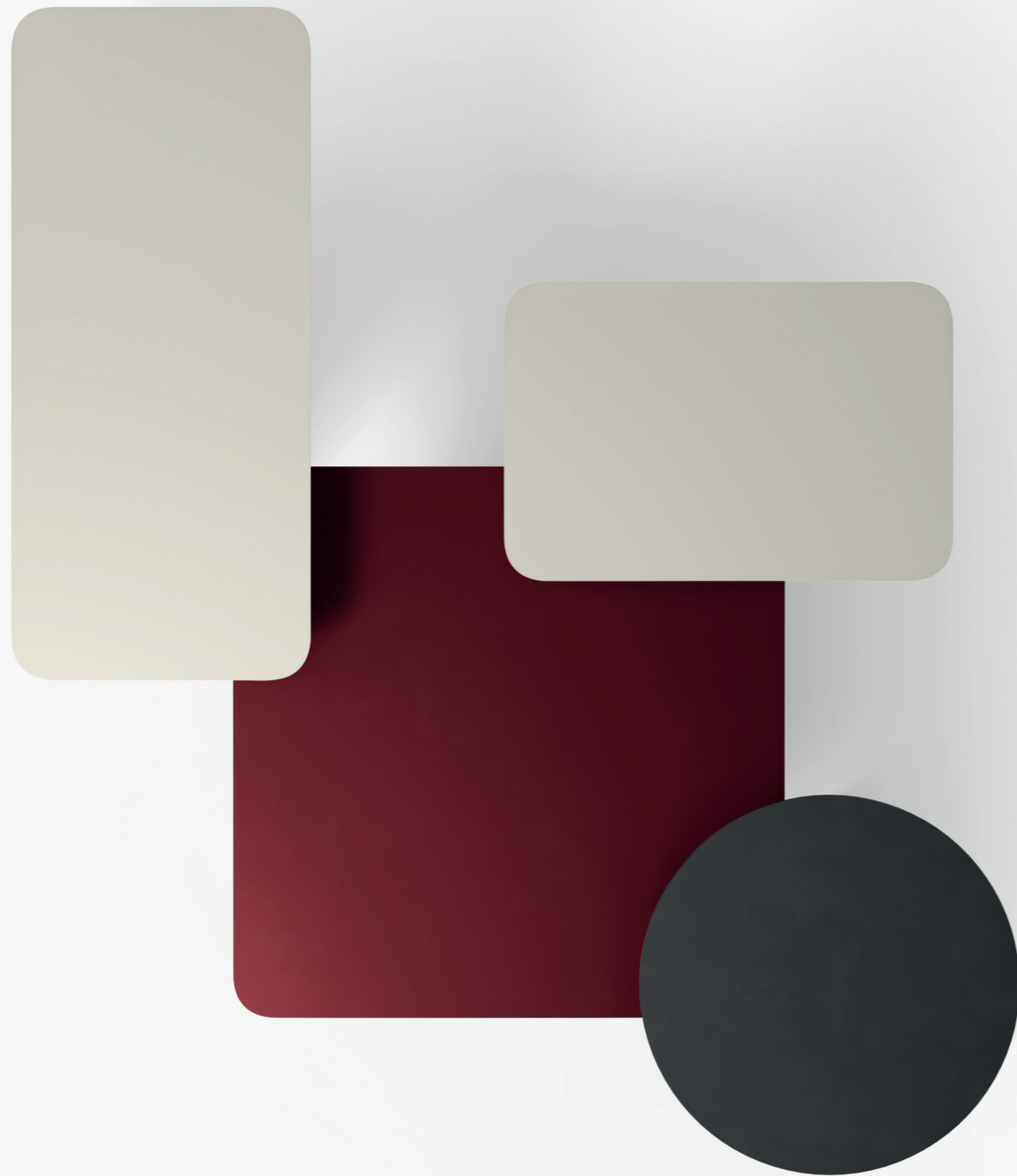

Dati tecnici - Technical data - Données techniques - Technische Angaben

		<b>A.</b> Alluminio <b>B.</b> Legno di rovere	<b>A.</b> Aluminium <b>B.</b> Oak wood
		<b>A.</b> Aluminium <b>B.</b> Bois de chêne	<b>A.</b> Aluminium <b>B.</b> Eichenholz

Finiture in metallo - Metal finishes - Finitions metal - Metallausführungen

Avorio Ivory Elfenbein	Fango Mud Boue Schlamm	Prugna Plum Prune Pflaume	Cioccolato Chocolate Chocolat Schokolade	Nero pece Pitch black Poix noir Pech Schwarz	Tè verde Green tea Thé vert Grüner Tee	Fiordaliso Cornflower Bleuet Kornblume
Laccato bronzo Lacquered bronze Laqué bronze Bronze lackiert	Laccato ottone Lacquered brass Laqué laiton Messing lackiert	Laccato rame Lacquered copper Laqué cuivre Kupfer lackiert				

Finiture in legno - Wooden finishes - Finitions bois - Holzausführungen

Rovere spazzolato naturale Natural brushed oak Chêne brossé naturel Eichenholz Natural gebürstet	Rovere spazzolato grafite Graphite brushed oak Chêne brossé graphite Eichenholz Graphit gebürstet

cod. 1100 / metal\_coffee table      cod. 1101 / metal\_coffee table      cod. 1102 / metal\_coffee table      cod. 1103 / metal\_coffee table

--	--	--	--

cod. 1104 / wood\_coffee table      cod. 1105 / wood\_coffee table      cod. 1106 / wood\_coffee table      cod. 1107 / wood\_coffee table

--	--	--	--



---

**LaCividina srl**

---

**HEADQUARTERS  
/ PRODUCTION**

Via Cividina 176  
33035 Martignacco  
Udine Italy

**SHOWROOM**

Via Lungolavia 1  
33035 Martignacco  
Udine Italy

T. + 39 0432 677433  
F. + 39 0432 677480  
info@lacidina.com  
www.lacidina.com



---

**Press Office**

---

Carter&Bennett  
pr@carterandbennett.com  
tel. +39 0432 1746101

/ La Cividina s.r.l., al fine di migliorare caratteristiche tecniche e qualitative della sua produzione, si riserva di apportare, anche senza preavviso, tutte le modifiche che si rendessero necessarie.

/ With a view to improving the technical characteristics and quality of its products, La Cividina s.r.l. reserves the right to develop its products at any time without notice.

/ Afin d'améliorer les caractéristiques techniques et qualitatives de sa production, La Cividina s.r.l. se réserve d'apporter, même sans préavis, toutes les modifications qui se rendront nécessaires.

/ Zur Verbesserung der technischen und qualitativen Merkmale behält sich La Cividina s.r.l. vor, alle notwendig erscheinenden Produktionsänderungen auch ohne Vorankündigung durchzuführen.

---

**Company Art Director**

---

Luca Botto

---

**Graphic Design**

---

Designwork

---

**Photo**

---

Alessandro Paderni / Studio Eye

---

**Render**

---

Nudesign Studio

---

**2D/3D development**

---

Federico Bravo

---

**Colour Separation**

---

Luce Group

---

**Copywriting**

---

Carter&Bennett

---

**Translation**

---

Trad&Co

---

**Made and printed in Italy**

---

Grafiche Manzanesi

April 2019



**LaCividina s.r.l**

**HEADQUARTERS  
/ PRODUCTION**

Via Cividina 176  
33035 Martignacco  
Udine Italy

**SHOWROOM**

Via Lungolavia 1  
33035 Martignacco  
Udine Italy

T. + 39 0432 677433

F. + 39 0432 677480

[info@lacividina.com](mailto:info@lacividina.com)

[www.lacividina.com](http://www.lacividina.com)