Jango

Family

Small armchair / Small sofa

Designer

Gianni Rossetti / 1996

Link

www.read-mo.re/jango



JANGO

Dati tecnici · Technical data · Données techniques · Technische Angaben

_swivel round base

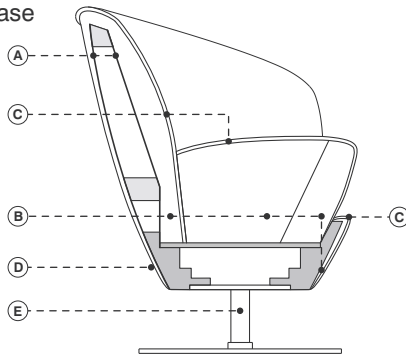

- Legno massiccio di abete
- Legno massiccio di faggio
- A. Pannello di masonite
- B. Poliuretano espanso ignifugo indeformabile a quote differenziate
- C. Fibra di poliestere
- D. Rivestimento fisso in tessuto o pelle
- E. Acciaio

- Solid fir
- Solid beech
- A. Masonite panel
- B. Flame-retardant undeformable polyurethane foam of different densities
- C. Polyester fibers
- D. Fixed upholstery in fabric or leather
- E. Steel

_swivel cross base

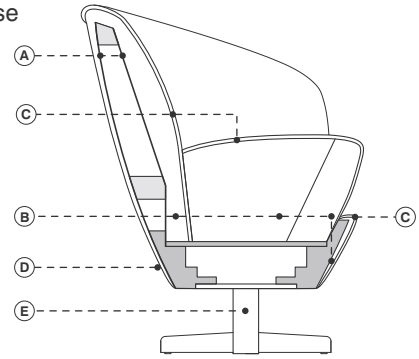

- Bois de sapin massif
- Bois de hêtre massif
- A. Panneau de particules
- B. Mousse polyuréthane expansé ignifuge indéformable à épaisseurs différenciées
- C. Fibre de polyester
- D. Revêtement pas déhoussable en tissu ou cuir
- E. Acier

- Massivholz aus Tanne
- Massivholz aus Buche
- A. Holzfaserplatte
- B. Feuerfester formbeständige Polyurethanschäum in unterschiedlicher Dichte
- C. Polyester
- D. Unabziehbarer Bezug aus Stoff oder Leder
- E. Stahl

Note · Notes · Annotation · Anmerkung

- Base personalizzabile con tinta cliente
- Cuscini extra disponibili
- COM: tessuto cliente (tinta unita e h.140 cm.) - campione richiesto
- COL: pelle cliente - campione richiesto
- CAT. SPECIAL: prezzo e disponibilità su richiesta

- Base customizable with customer's colors on request
- Extra cushions available
- COM: client's fabric (plain colour and width 140 cm.) - sample required
- COL: client's leather - sample required
- CAT. SPECIAL: price and availability on request

- Piètement disponible en autres finitions sur demande
- Autres coussins disponibles
- COM: tissu fourni (couleur unie et hauteur 140 cm.) - échantillon nécessaire
- COL: cuir fourni - échantillon nécessaire
- CAT. SPECIAL: prix et disponibilité sur demande

- Gestell in Kundenfarben auf Anfrage verfügbar
- Weitere Kissen verfügbar
- COM: Kundenstoff (einfarbig und Breite 140 cm.) - Stoffmuster nötig
- COL: Kundenleder - Ledermuster nötig
- CAT. SPECIAL: Preis und Verfügbarkeit auf Anfrage

Finiture base · Base finishes · Finitions piètement · Gestell Ausführungen



Cromato lucido
Polished chrome steel
Acier chromé brillant
Stahl Chrom poliert



Nero (RAL 9005)
Black (RAL 9005)
Noir (RAL 9005)
Schwarz (RAL 9005)

Rivestimenti consigliati · Recommended coverings · Revêtements conseillées · Empfohlene Bezüge

• cat. A	XTREME	• cat. C	SUPERB	• cat. extra	RIME	• cat. maxi	HALLINGDAL 65
• cat. A	TAILOR	• cat. C	DEANS	• cat. extra	MOLLY 2	• cat. maxi	DIVINA 3
• cat. A	ANGEL	• cat. C	IRIS	• cat. extra	STEELCUT TRIO 3	• cat. top	ARDA
• cat. A	SAMAR	• cat. C	TREND	• cat. extra	ARIANA	• cat. special	GENTLE 2
• cat. A	AVON	• cat. super	AMELIA	• cat. extra	COLLINE	• cat. special	SISU
• cat. A	MAGNUM	• cat. super	NOX	• cat. extra	OPERA	• cat. lux	LUX 1
• cat. A	CRAZY	• cat. super	ORSETTO	• cat. extra	ARCO	• cat. lux	LUX 2
• cat. B	WILSON	• cat. super	REMIX 3	• cat. extra	CREDO	• cat. imperial	IMPERIAL 1
• cat. B	FAME	• cat. super	TERASKIN	• cat. extra	CLEO	• cat. imperial	IMPERIAL 2
• cat. B	MAIN LINE FLAX	• cat. super	FOSTER	• cat. extra	TRIO		
• cat. B	HERO			• cat. extra	BIT		
• cat. B	HESTAN						
• cat. B	SATEN						
• cat. B	SILVERTEX						

cod. 3032 / swivel armchair with cross base

cod. 2030 / swivel armchair with base

cod. 2031N / 2 seater

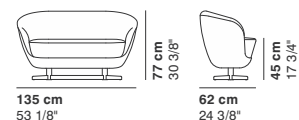
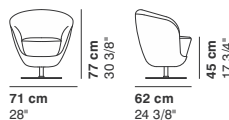
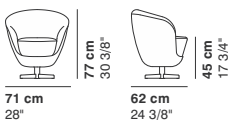

La Cividina s.r.l., al fine di migliorare caratteristiche tecniche e qualitative della sua produzione, si riserva di apportare, anche senza preavviso, tutte le modifiche che si rendessero necessarie.

With a view to improving the technical characteristics and quality of its products, La Cividina s.r.l. reserves the right to develop its products at anytime without notice.

Afin d'améliorer les caractéristiques techniques et qualitatives de sa production, La Cividina s.r.l. se réserve d'apporter, même sans préavis, toutes les modifications qui se rendront nécessaires.

Zur Verbesserung der technischen und qualitativen Merkmale, behält sich La Cividina s.r.l. vor, alle notwendig erscheinenden Produktionsänderungen, auch ohne Vorankündigung durchzuführen.



ISO 9001

LaCividina srl

**HEADQUARTERS
/ PRODUCTION**

Via Cividina 176
33035 Martignacco
Udine Italy

SHOWROOM

Via Lungolavia 1
33035 Martignacco
Udine Italy

T. + 39 0432 677433

F. + 39 0432 677480

info@lacividina.com

www.lacividina.com

VAT nr. IT01810870301